

MODEL 1261B

HIGH POWER INTELLIGENT MAINFRAME VXI CHASSIS

PUBLICATION NO. 980766

RACAL INSTRUMENTS

United States

(Corporate Headquarters and Service Center)
4 Goodyear Street, Irvine, CA 92618

Tel: (800) 722-2528, (949) 859-8999; Fax: (949) 859-7139

5730 Northwest Parkway Suite 700, San Antonio, TX 78249

Tel: (210) 699-6799; Fax: (210) 699-8857

Europe

(European Headquarters and Service Center)
18 Avenue Dutartre, 78150 LeChesnay, France

Tel: +33 (0)1 39 23 22 22; Fax: +33 (0)1 39 23 22 25

29-31 Cobham Road, Wimborne, Dorset BH21 7PF, United Kingdom

Tel: +44 (0) 1202 872800; Fax: +44 (0) 1202 870810

Via Milazzo 25, 20092 Cinisello B, Milan, Italy

Tel: +39 (0)2 6123 901; Fax: +39 (0)2 6129 3606

Technologie Park, Friedrich Ebert Strasse, 51429 Bergisch Gladbach, Germany

Tel: +49 (0) 2204 844200; Fax: +49 (0) 2204 844219

info@racalstruments.com
sales@racalstruments.com
helpdesk@racalstruments.com
<http://www.racalstruments.com/>



PUBLICATION DATE: October 28, 2004

Copyright 1995 by Racal Instruments, Inc. Printed in the United States of America. All rights reserved.
This book or parts there of may not be reproduced in any form without written permission of the publisher.

THANK YOU FOR PURCHASING THIS RACAL INSTRUMENTS PRODUCT

For this product, or any other Racal Instruments product that incorporates software drivers, you may access our web site to verify and/or download the latest driver versions. The web address for driver downloads is:
<http://www.racalinstruments.com/downloads>

If you have any questions about software driver downloads or our privacy policy, please contact us at
info@racalinstruments.com.

WARRANTY STATEMENT

All Racal Instruments, Inc. products are designed and manufactured to exacting standards and in full conformance to Racal's ISO 9000/2000 procedures.

For the specific terms of your standard warranty, or optional extended warranty or service agreement, contact your Racal customer service advisor. Please have the following information available to facilitate service.

1. Product serial number
2. Product model number
3. Your company and contact information

You may contact your customer service advisor by:

E-Mail:	Helpdesk@racalinstruments.com	
Telephone:	+1 800 722 3262	(USA)
	+44(0) 8706 080134	(UK)
Fax:	+1 949 859 7309	(USA)
	+44(0) 1628 662017	(UK)

RETURN of PRODUCT

Authorization is required from Racal Instruments before you send us your product for service or calibration. Call your nearest Racal Instruments support facility. A list is located on the last page of this manual. If you are unsure where to call, contact Racal Instruments, Inc. Customer Support Department in Irvine, California, USA at 1-800-722-3262 or 1-949-859-8999 or via fax at 1-949-859-7139. We can be reached at:
helpdesk@racalinstruments.com.

PROPRIETARY NOTICE

This document and the technical data herein disclosed, are proprietary to Racal Instruments, and shall not, without express written permission of Racal Instruments, be used, in whole or in part to solicit quotations from a competitive source or used for manufacture by anyone other than Racal Instruments. The information herein has been developed at private expense, and may only be used for operation and maintenance reference purposes or for purposes of engineering evaluation and incorporation into technical specifications and other documents which specify procurement of products from Racal Instruments.

DISCLAIMER

Buyer acknowledges and agrees that it is responsible for the operation of the goods purchased and should ensure that they are used properly and in accordance with this handbook and any other instructions provided by Seller. Racal Instruments products are not specifically designed, manufactured or intended to be used as parts, assemblies or components in planning, construction, maintenance or operation of a nuclear facility, or in life support or safety critical applications in which the failure of the Racal Instruments product could create a situation where personal injury or death could occur. Should Buyer purchase Racal Instruments product for such unintended application, Buyer shall indemnify and hold Racal Instruments, its officers, employees, subsidiaries, affiliates and distributors harmless against all claims arising out of a claim for personal injury or death associated with such unintended use.

FOR YOUR SAFETY

Before undertaking any troubleshooting, maintenance or exploratory procedure, read carefully the **WARNINGS** and **CAUTION** notices.



CAUTION
RISK OF ELECTRICAL SHOCK
DO NOT OPEN



This equipment contains voltage hazardous to human life and safety, and is capable of inflicting personal injury.



If this instrument is to be powered from the AC line (mains) through an autotransformer, ensure the common connector is connected to the neutral (earth pole) of the power supply.



Before operating the unit, ensure the conductor (green wire) is connected to the ground (earth) conductor of the power outlet. Do not use a two-conductor extension cord or a three-prong/two-prong adapter. This will defeat the protective feature of the third conductor in the power cord.



Maintenance and calibration procedures sometimes call for operation of the unit with power applied and protective covers removed. Read the procedures and heed warnings to avoid “live” circuit points.

Before operating this instrument:

1. Ensure the proper fuse is in place for the power source to operate.
2. Ensure all other devices connected to or in proximity to this instrument are properly grounded or connected to the protective third-wire earth ground.

If the instrument:

- fails to operate satisfactorily
- shows visible damage
- has been stored under unfavorable conditions
- has sustained stress

Do not operate until, performance is checked by qualified personnel.

Racal Instruments

EC Declaration of Conformity

We

Racal Instruments Inc.
4 Goodyear Street
Irvine, CA 92718

declare under sole responsibility that the

1261B High Performance VXI bus Mainframe, P/N 407374-XXXXX

conforms to the following Product Specifications:

Safety: EN61010-1:1993+A2:1995

EMC: EN61326:1997+A1:1998

Supplementary Information:

The product herewith complies with the requirements of the Low Voltage Directive 73/23/EEC and the EMC Directive 89/336/EEC (modified by 93/68/EEC).

Irvine, CA, May 08, 2002

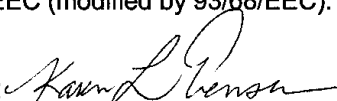
Engineering Director

This page was left intentionally blank.

Table of Contents

Chapter 1

Getting Started	1-1
Product Description	1-1
Key Features	1-1
Ease of Use	1-1
Bench Top Model (7U Footprint)	1-2
VXI <i>plug&play</i> Rack Mount Model (9U Footprint)	1-3
Modular Mainframe Design.....	1-4
2000 Watts Available DC Power.....	1-5
High Capacity Positive Pressure Cooling System.....	1-6
Bench Top Cooling System	1-6
Rack Mount Cooling System.....	1-7
Advanced System Monitoring	1-8
Standard System Monitor (SMS)	1-8
Enhanced System Monitor (EMS).....	1-8
Rack Mount Features	1-9
Backplane	1-9
Items Shipped With The 1261B.....	1-10
Spares Ordering Information	1-10

Chapter 2

Configuring The 1261B.....	2-1
Using This Chapter.....	2-1
AC Mains Power.....	2-1
Site Considerations	2-1
Installing VXI Modules	2-2
Installation and Removal of Card Guide Covers (Airflow Directors).....	2-2
Installing Blanking Panels.....	2-3
Installing The Rack Mount Options.....	2-4
Installing The Slides Into The Rack	2-8

Preparing The Mainframe For Rack Mounting (Omit steps 4 and 5 for options without slides)	2-11
Installing The Mainframe into The Rack (Omit step 1 for options without slides)	2-11
Installing Option 54-1 and 54-2 Receiver Front Extension	2-12
Installing Inter-Module Shields Option 52	2-12
Installing ASFP Panel Option 23	2-12
Installing Rack Mount Door	2-12
Connecting Safety Ground	2-15
Fan Speed Range (HI - LO) Selection (For Models With System Monitor)	2-16
Installing the Enhanced Monitoring System (EMS)	2-17
Enhanced Monitor VXI Logical Address Switch	2-17
Enhanced Monitor Configuration Switch	2-18
Connecting The RS-232 Interface	2-19
Connecting To a Computer, Data Terminal, or Modem	2-19
RS-232 Flow Control Method	2-19
RS-232 Echo Back Considerations	2-19
Installing The <i>VXIplug&play</i> Software	2-23
 Chapter 3	
Operating The 1261B	3-1
Using This Chapter	3-1
Front Panel When Equipped With Standard Monitoring System	3-2
Rear Panel When Equipped With Standard Monitoring System	3-3
Front Panel When Equipped With Enhanced Monitoring System	3-4
Rear Panel When Equipped With Enhanced Monitoring System	3-5
Powering On The Mainframe	3-6
Using Remote Power On/Standby Switching	3-7
Monitoring Basics	3-8
Rear Panel Switch and Connector Descriptions	3-10
Basic Functional Check	3-15
 Chapter 4	
Using The Enhanced Monitoring System	4-1
Overview	4-1
Power On/Reset Defaults	4-1
What To Do Now	4-3

Measuring Power Supply Voltages	4-3
Measuring Power Supply Currents	4-3
Measuring Ambient Temperature	4-3
Measuring VXI Slot Temperature	4-4
Measuring Fan Speed	4-4
Measuring Elapsed Time	4-5
Reading The Present State of VXI Signals	4-5
Monitoring The VXI Subsystem	4-6
Programming The Tolerance Limits.....	4-6
Programming The Power Supply Voltage Tolerance Limits	4-7
Programming The Power Supply Current Tolerance Limits	4-7
Programming The Fan Speed Tolerance Limits	4-8
Programming The Ambient Temperature Tolerance Limits	4-8
Programming The VXI Slot Temperature Tolerance Limits	4-9
Programming The VXI Bus Error and IACKn Tolerance Limits.....	4-11
Reading The VXI Bus Error and IACKn Counters.....	4-11
Clearing The VXI Bus Error and IACKn Counters.....	4-12
Generating an Interrupt When an Alarm Condition is Detected	4-12
Clearing The Filter Service Alarm.....	4-22
Change of Limit for Filter Service Alarm Example	4-23
Interrupt Generation Example	4-23
Programming The Trigger Subsystem.....	4-25
Connecting The TRIG IN Input To a TTLTRG Line	4-25
Connecting The TRIG OUT Output To a TTLTRG Line.....	4-26
Discrete Fault Indicator.....	4-27
Programming the Discrete Fault Indicator	4-27
Testing the DFI Operation	4-28
Programming a Trigger Delay Time	4-28
Selecting The Trigger Delay Application.....	4-29
Programming The Front Panel Display.....	4-29
Turning The Display On and Off.....	4-30
Writing a Message To The Display.....	4-30
Clearing The Message From The Display	4-31
Front Panel Message Semantics.....	4-32
Front Panel Status Messages.....	4-32

Programming The RS-232 Interface	4-34
Programming The Baud Rate.....	4-34
Programming The Number of Data Bits	4-35
Programming The Parity	4-35
Programming The Number of Stop Bits.....	4-35
Illegal RS-232 Interface Combinations	4-36
Setting The System Time and Date.....	4-37
Reading Event Time Stamps.....	4-38
IEEE-488.2 Common Commands	4-39
*IDN? Query.....	4-39
*RST Command.....	4-40
*TST? Query	4-40
*CLS Command	4-40
*ESE Command.....	4-40
*ESE? Query.....	4-41
*ESR? Query	4-41
*SRE Command.....	4-42
*SRE? Query	4-42
*STB? Query.....	4-43
*OPC Command	4-43
*OPC? Query	4-44
*RCL Command.....	4-44
*SAV Command.....	4-45
*TRG Command	4-45
*WAI Command	4-45
Performing The Self Test	4-45
Chapter 5	
SCPI COMMAND REFERENCE.....	5-1
What's In This Chapter	5-1
Introduction To SCPI Language	5-1
Command Keyword Long Form and Short Form	5-2
Case Sensitivity.....	5-2
Optional Keywords	5-3
Multiple Identical Capabilities and Keyword Suffixes	5-3

The MIN, MAX, and DEF Parameters.....	5-4
Querying Parameter Setting	5-4
Query Response Format	5-5
SCPI Command Terminator	5-5
IEEE-STD-488.2 Common Commands	5-5
SCPI Parameter Type	5-5
Numeric Parameters	5-6
Discrete Parameters.....	5-6
Boolean Parameters.....	5-6
SCPI Command Summary	5-6
Command Parameter Limits.....	5-10
Device Specific Commands.....	5-11
Chapter 6	
UNDERSTANDING The 1261B	6-1
Overview	6-1
Power Supply	6-1
Power Supply Interconnection	6-1
Power Supply Protections	6-3
Backplane	6-3
Backplane Interconnections.....	6-4
Cooling System	6-4
Rack Mount Cooling System.....	6-4
Bench Top Cooling System	6-4
Cooling The Power Supply.....	6-5
Standard Monitoring System	6-5
SMS Fan Speed Monitor.....	6-5
SMS Fan Speed Control	6-5
SMS Fan Speed Switch	6-5
SMS Temperature Monitor.....	6-5
SMS Voltage Monitoring	6-6
SMS Current Monitoring	6-6
Enhanced System Monitor (EMS).....	6-6
EMS Module System Interconnection	6-8
EMS Module General Capabilities	6-8

User Limits On EMS Monitored Parameters	6-9
Timestamps On EMS Monitored Events	6-9
EMS Rear Panel Fan Speed Monitor	6-9
EMS Fan Speed Control	6-9
EMS Fan Speed Switch	6-10

Chapter 7

MAINTENANCE	7-1
What's In This Chapter	7-1
Service Strategy	7-1
Service Interval	7-1
Preparation	7-1
Inspection and Cleaning	7-2
Interior Cleaning	7-2
Exterior Cleaning	7-2
Cleaning The Power Supply Filter	7-3
Cleaning The Module Fan Filter	7-4
Modular Component Removal and Replacement	7-5
Tools Required	7-6
Removal and Replacement of The Module Fan Assembly	7-6
Removal and Replacement of The Power Supply Assembly	7-8
Removal and Replacement of The System Monitor	7-11
Removal and Replacement of The AC Mains Fuse	7-13
Removing and Replacing The Card Guides	7-14
Troubleshooting The 1261B	7-15

Chapter 8

PRODUCT SUPPORT	8-1
Product Support	8-1
Reshipment Instructions	8-1
Support Offices	8-2

List of Figures

Figure 1-1, 1261B Bench Top (7U Tall) Mainframe.....	1-2
Figure 1-2, 1261B Rack Mount (9U Tall) Mainframe.....	1-3
Figure 1-3, Modular Service Friendly Mainframe Design Features.....	1-4
Figure 1-4, 1261B High Power Pluggable Power Supply	1-5
Figure 1-5, 1261B Bench Top Mainframe Positive Pressure Cooling System	1-6
Figure 1-6, 1261B Rack Mount Mainframe Positive Pressure Cooling System	1-7
Figure 1-7, 1261B System Monitor Components.....	1-8
Figure 1-8, Rack Mount and Cable Tray Option Components.....	1-9
Figure 2-1, Airflow Directors.....	2-2
Figure 2-2, Blanking Panels.....	2-3
Figure 2-3, Rack Mount Options Major Components	2-4
Figure 2-4, Slide and Bracket Components(9U Rack Mount Mainframe)	2-5
Figure 2-5, Preparing The Mainframe For Rack Mounting	2-6
Figure 2-6, Rear End Slide Mount Rack Dimension	2-10
Figure 2-7, Instrument Rail Removal.....	2-10
Figure 2-8, Installing Rack Door.....	2-14
Figure 2-9, Connecting Safety Ground.....	2-15
Figure 2-10, Fan Speed Range (HI -LO) Selection	2-16
Figure 2-11, Setting The Enhanced Monitor VXI Logical Address.....	2-17
Figure 2-12, Setting the Enhanced Monitoring System Configuration Switch.....	2-18
Figure 2-13, Setting Up The Enhanced Monitoring System RS232 Interface	2-20
Figure 2-14, RS-232 Connections With a Computer, Data Terminal or Modem	2-22
Figure 3-1, 1261B Front View With Standard Monitor.....	3-2
Figure 3-2, 1261B Rear View with Standard Monitor.....	3-3
Figure 3-3, Front View With Enhanced Monitor.....	3-4
Figure 3-4, Rear View With Enhanced Monitor	3-5
Figure 3-5, Powering On The Mainframe	3-6
Figure 3-6, Using Remote Power On/Standby Switching	3-7

Figure 4-1, Voltage Condition Register	4-13
Figure 4-2, Event and Enable Registers and Summary Bit Generation.....	4-18
Figure 4-3, Status Reporting Hierarchy.....	4-21
Figure 6-1, Functional Block Diagram For 1261B Chassis.....	6-2
Figure 6-2, Enhanced Monitoring System Module Block Diagram	6-7
Figure 7-1, Cleaning The Supply Fan Filter	7-3
Figure 7-2, Cleaning The Module Fan Filter.....	7-4
Figure 7-3, Module Fan Assembly Detail	7-7
Figure 7-4, Aligning The Module Fan Assembly.....	7-8
Figure 7-5, Power Supply Rear View	7-9
Figure 7-6, Removing The Power Supply	7-10
Figure 7-7, Monitor System Module Rear View.....	7-11
Figure 7-8, Monitoring System Module Removal and Replacement.....	7-12
Figure 7-9, Removing and Replacing The AC Mains Fuse	7-13
Figure 7-10, Card Guide Removal and Replacement	7-14

List of Tables

Table 1-1, 1261B Available DC Current	1-5
Table 2-1, Rack Mount Components.....	2-7
Table 2-2, Door Components.....	2-14
Table 3-1, Monitoring Basics.....	3-8
Table 3-2, SMS Rear Panel Switches	3-10
Table 3-3, EMS Rear Panel Switches	3-10
Table 3-4, J410 SMS Rear Panel Monitor	3-11
Table 3-5, J412 EMS RS-232 Port.....	3-12
Table 3-6, J413 EMS TTL Trigger Connector	3-12
Table 3-7, J414 EMS Rear Panel Monitor	3-13
Table 3-8, J415 Rear Panel Monitor/Control Connector.....	3-14
Table 3-9, Power Supply Voltages at J415	3-15
Table 4-1, Default Limit Settings After Power On, *RST	4-2
Table 4-2, Voltage Condition and Event Register Bit Assignments	4-14
Table 4-3, Current Condition and Event Register Bit Assignments	4-14
Table 4-4, Temperature Condition and Event Register Bit Assignments.....	4-15
Table 4-5, Fan Speed Condition and Event Register Bit Assignments.....	4-15
Table 4-6, Time Condition and Event Register Bit Assignments	4-16
Table 4-7, VXI Condition and Event Register Bit Assignments	4-16
Table 4-8, Questionable Condition Register Bit Assignment	4-19
Table 4-9, Front Panel Status Messages	4-33
Table 5-1. VXIbus Model 1261B EMS SCPI Commands List Summary.....	5-7
Table 5-2, Defaults, Minima and Maxima	5-10
Table 7-1, Troubleshooting	7-16

This page was left intentionally blank.

Chapter 1

GETTING STARTED

Product Description

The Model 1261B High Power Intelligent Mainframe is a 13-slot VXIbus Mainframe. It fully complies with the VXIbus Specification 1.4 requirements and is *VXIplug&play* compatible.

Key Features

Figures 1-1 through 1-8 show the key features of the 1261B.

Ease of Use

- **Fast Setup.** The 1261B backplane uses active-automatic VME interrupt acknowledge and bus grant daisy chaining. Manual configuration of backplane switch settings or jumpers has been eliminated.
- **Universal AC Input.** The 1261B AC input is both auto-voltage and auto-frequency ranging. The chassis does not require the configuration of a voltage selection switch.
- **Visual System Health Status Indication.** The 1261B comes standard with system monitoring that gives you key system health status (Voltage, Current, Airflow and Temperature) on the front panel display. Monitored parameters include temperature rise on each slot, fan speed, power supply voltage and currents.
- **Enhanced Monitoring.** The optional micro-controller based Enhanced Monitoring System (EMS) adds a fully VXIbus compliant message-based interface, an auxiliary RS-232 port, and *VXIplug&play* drivers. The alpha-numeric display that comes with the EMS provides detailed system status messages.
- **Plug-in Power Supply, Fans, and Monitor.** The 1261B modular system design results in a virtually wireless mainframe with low MTTR and high MTBF. See **Figure 1-3**.

- **Variable Recess Rack Mounting.** The adjustable rack mount ear provides variable (0.625 inch increments) recess rack mounting capability. See **Figure 1-8**.
- **Fan Speed Control.** The 1261B delivers the cooling air that your application requires. Fan speed control reduces acoustic noise levels of the 1261B high performance cooling system.

Bench Top Model (7U Footprint)

The 1261B Bench Top is a high performance VXI mainframe that is only 7U (12.220 inches) tall.

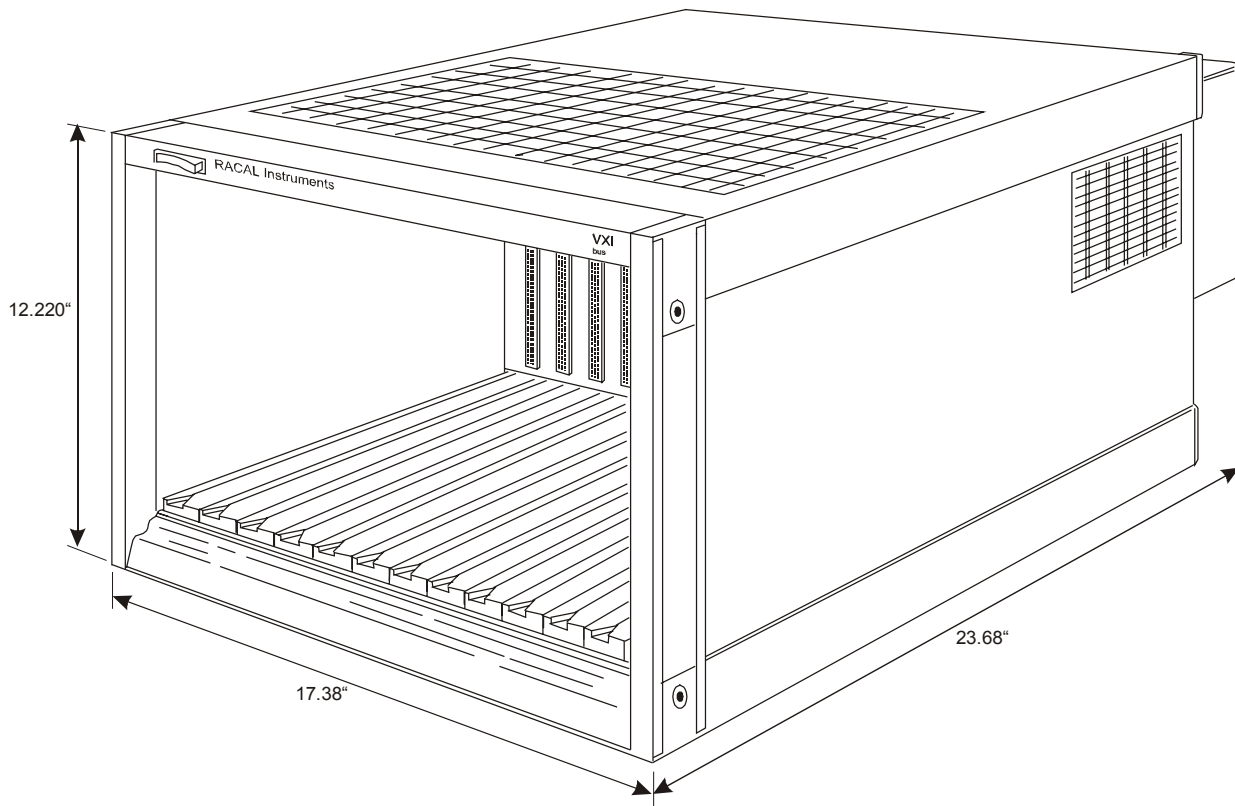

Figure 1-1, 1261B Bench Top (7U Tall) Mainframe

**VXIplug&play
Rack Mount
Model
(9U Footprint)**

The 1261B Rack Mount mainframe is designed to the VXIplug&play 9U tall (15.720 inches) footprint.

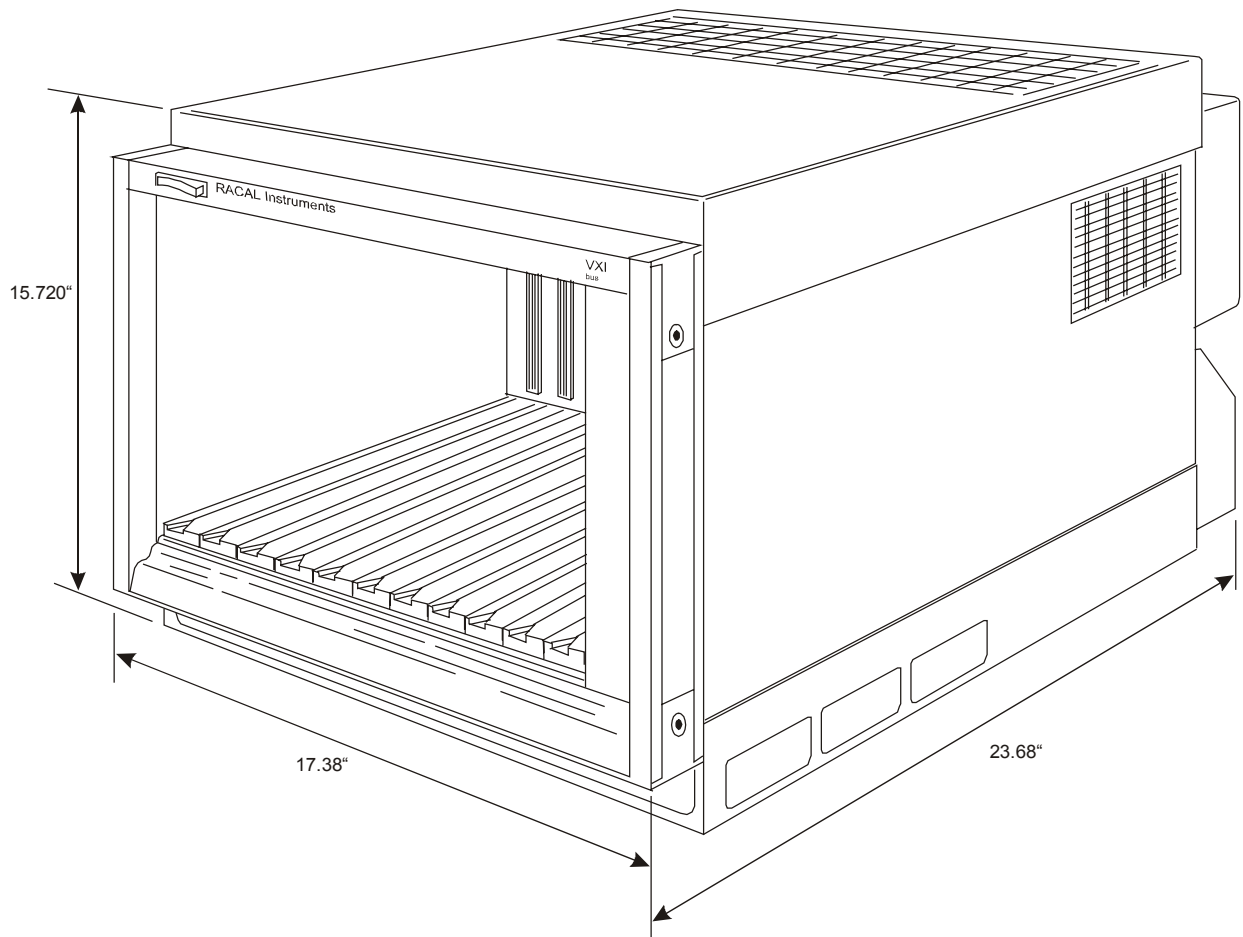

Figure 1-2, 1261B Rack Mount (9U Tall) Mainframe

Modular Mainframe Design

The 1261B highly modular design is virtually wireless with low MTTR and high MTBF.

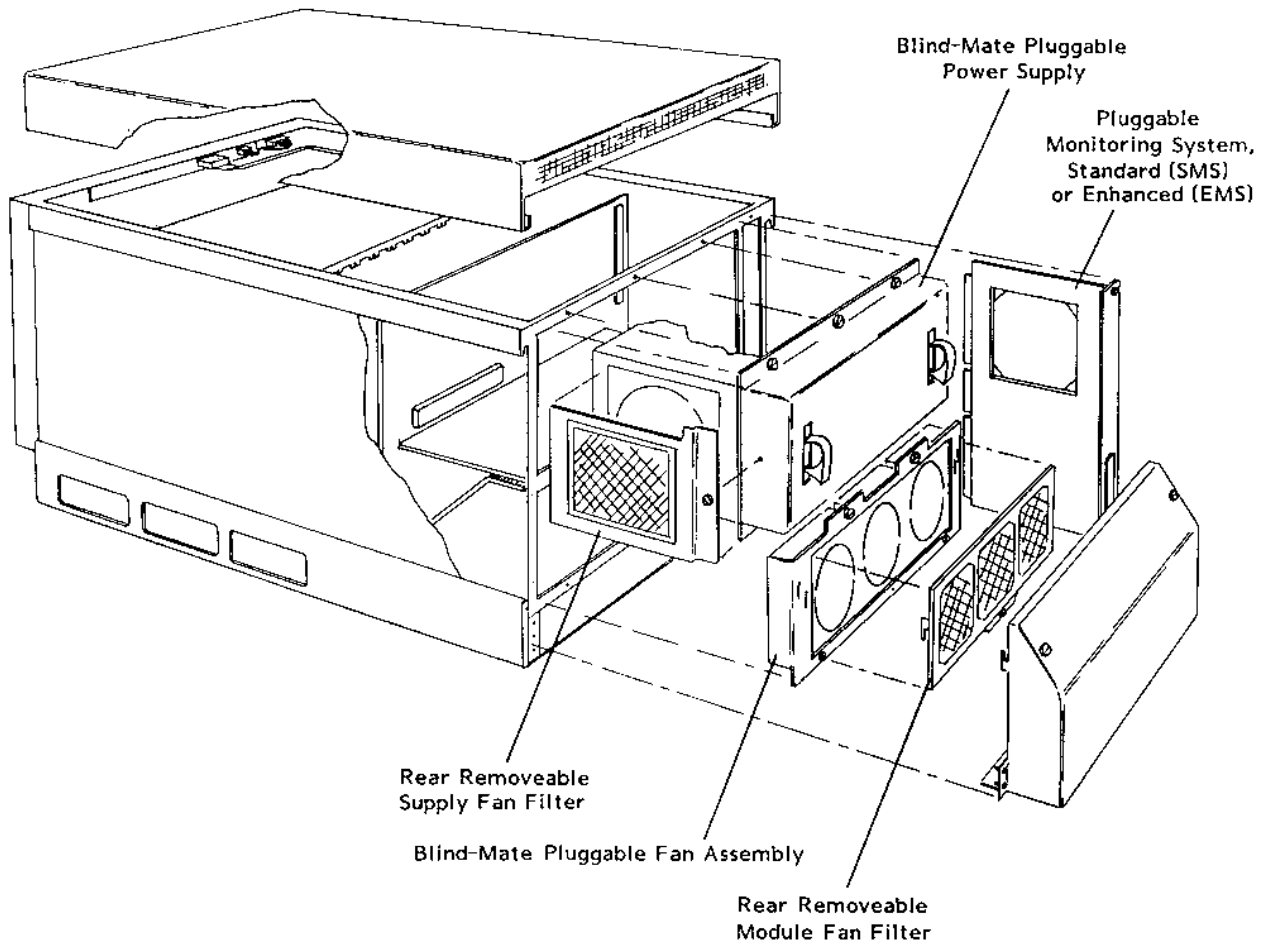

Figure 1-3, Modular Service Friendly Mainframe Design Features

2000 Watts Available DC Power

Figure 1-4 depicts the 1261B high power plug-in power supply. Table 1-1 lists the available DC current for each VXI voltage.

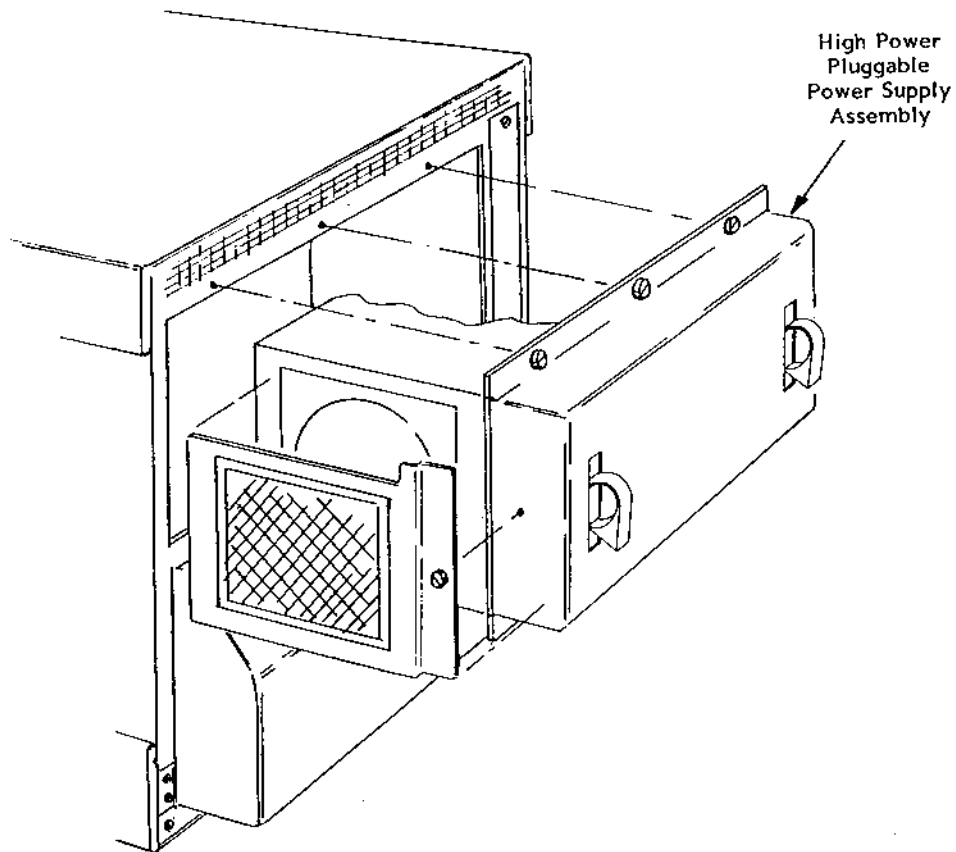

Figure 1-4, 1261B High Power Pluggable Power Supply

Table 1-1, 1261B Available DC Current

VXI Voltage	Available DC Current
+5V	80 Amps
-5.2V	60 Amps
-2V	30 Amps
+12V	17 Amps
-12V	17 Amps
+24V	12 Amps
-24V	12 Amps

High Capacity Positive Pressure Cooling System

The 1261B uses forced air positive pressure cooling to direct air to the VXI modules.

Bench Top Cooling System

Figure 1-5 details the bench top cooling system.

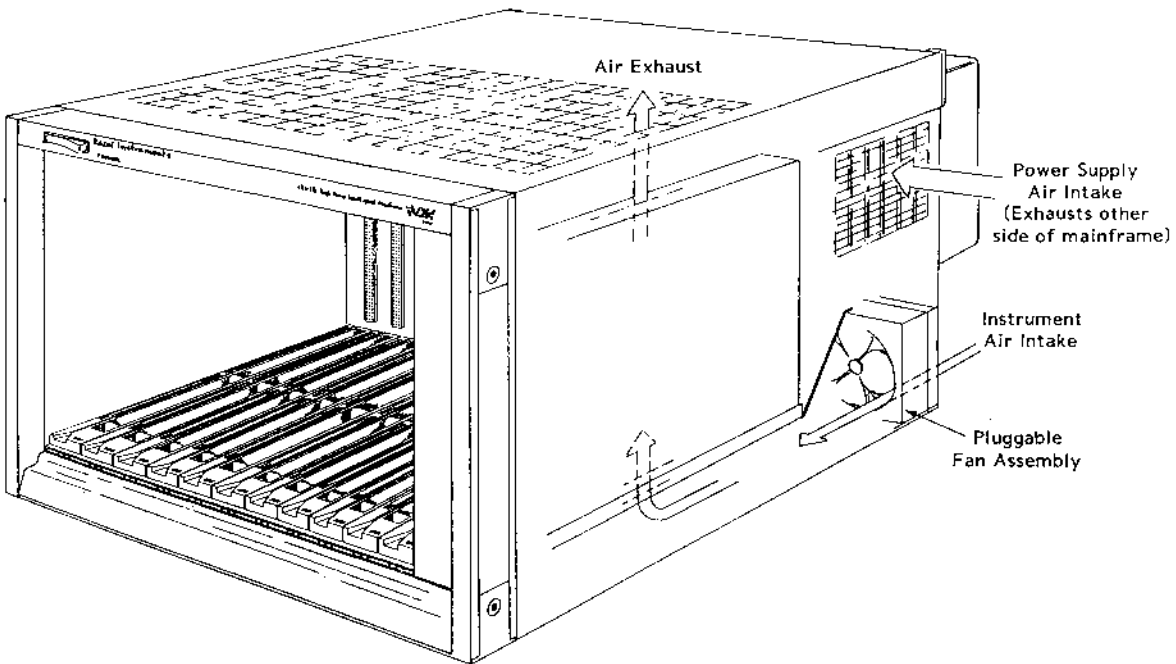

Figure 1-5, 1261B Bench Top Mainframe Positive Pressure Cooling System

Rack Mount Cooling System

Figure 1-6 details the 1261B Rack Mount cooling system. The 1261B Rack Mount has air intake at the bottom sides and exhausts at the top rear, consistent with industry standard rack mount cooling practice.

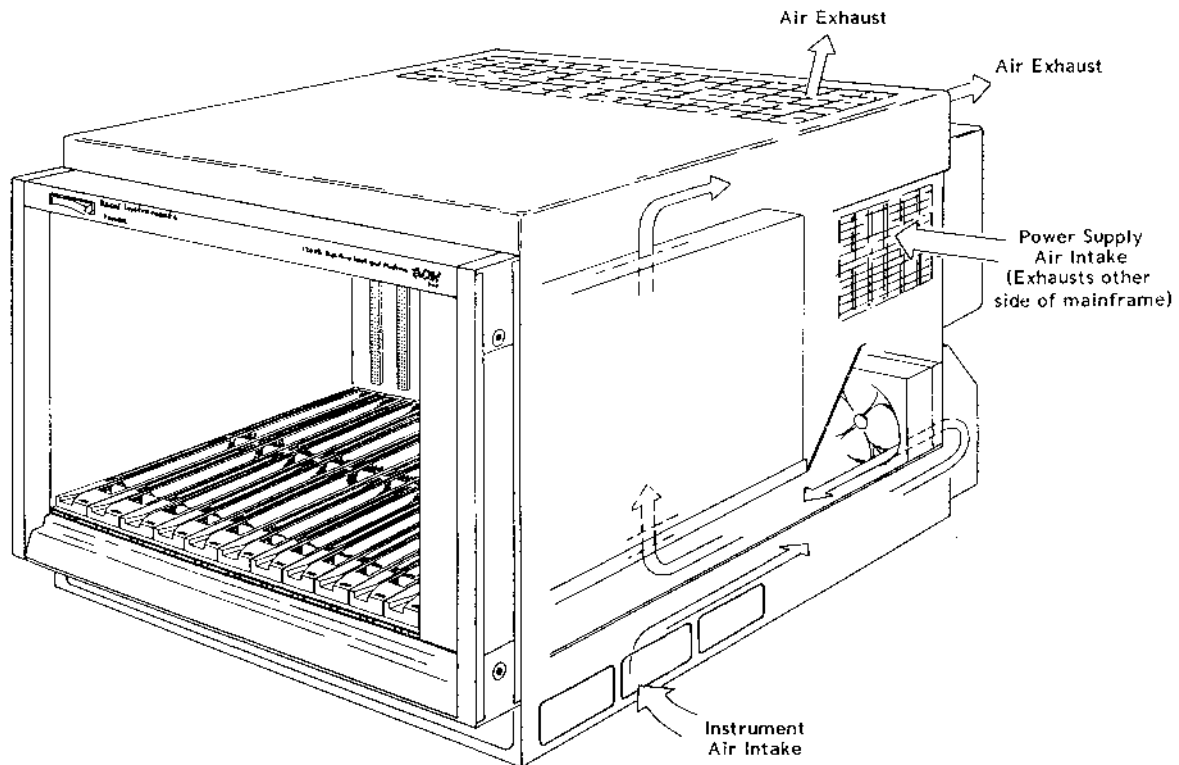

Figure 1-6, 1261B Rack Mount Mainframe Positive Pressure Cooling System

Advanced System Monitoring

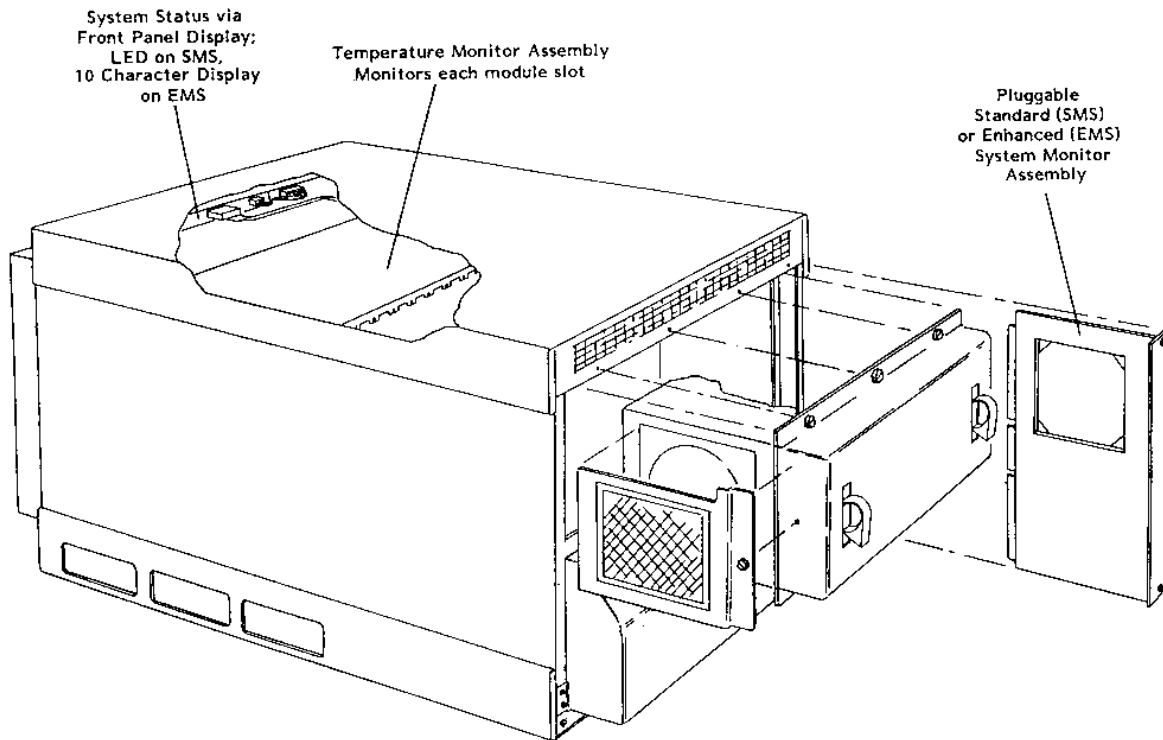

Figure 1-7, 1261B System Monitor Components

Standard System Monitor (SMS)

The Standard Monitoring System (SMS) features include temperature monitoring on each slot, fan speed sensing and control, power supply voltage and current monitoring. System health status is reported via front panel annunciators for Voltage, Current, Airflow, and Temperature alarm conditions.

Enhanced System Monitor (EMS)

The Enhanced Monitoring System adds a fully VXIbus 1.4 compliant message-based interface, alpha numeric display, individual VXIbus voltage and slot temperature reading, TTL trigger in/outputs with programmable delay, state monitoring of key VXI backplane signals (AS*, ACFAIL*, SYSRESET*), event counting of VXI bus error (BERR*) conditions and interrupt cycles. The EMS also comes complete with VXI *plug&play* drivers. See disks at back of manual, and driver installation in Chapter 2.

Rack Mount Features

The 1261B is available with a wide variety of options for both rack mount (9U) and bench top (7U) models.

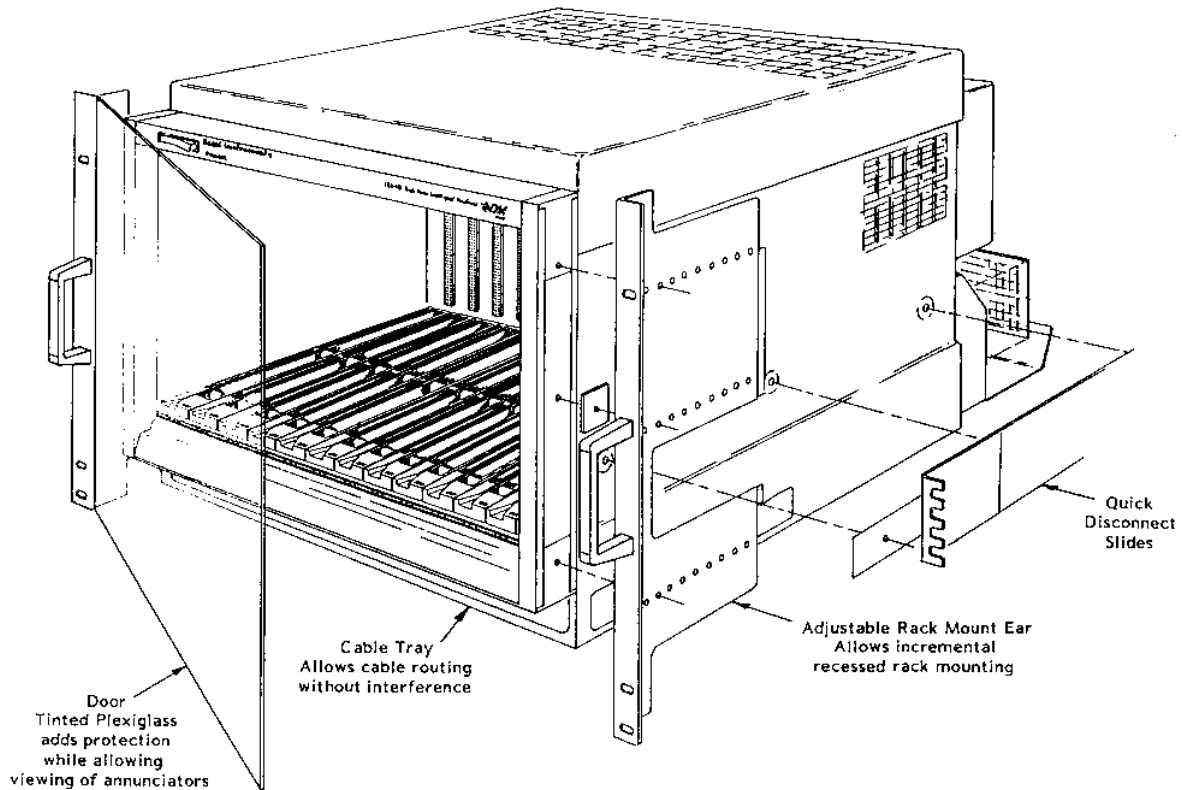

Figure 1-8, Rack Mount and Cable Tray Option Components

The adjustable rack mount ear provides variable recessed rack mounting capability.

Backplane

The 1261B has a jumperless auto-configurable backplane using active-automatic daisy chaining for the VME Interrupt acknowledge and bus grant daisy chain signal lines. This eliminates the need to manually configure the backplane.

Distribution of the CLK10 reference clock is full differential providing a low skew timing source.

Power is supplied to the backplane through a direct connection to the 1261B power supply eliminating wiring and sub-backplane interconnect boards. The result is increased reliability and improved dynamic current performance.

Items Shipped With The 1261B

Qty	Item	Part Number
1	Instruction Manual	980766
1	Power Cable	602262
6	Card Guide Covers	456271
1	VXI <i>plug&play</i> Software Driver WIN95/WINNT (included with manual)	921511

Spares Ordering Information

Spares Ordering Information		
Model	Description	Part Number
1261B Power Supply	Spare Power Supply Module	407377-910
1261B Fan Assembly	Spare High Power Fan Module	407375
SMS Module	Spare SMS Module	405092
EMS Module	Spare EMS Module	405094
Card Guide Cover	Spare Card Guide Cover	456271
Blanking Plate	Blanking Plates (to fill empty module slots)	404836
Front Door Assembly	Replacement Front Door (7U)	407429
Front Door Assembly	Replacement Front Door (9U)	407430

Optional Equipment

Options		
Model	Description	Part Number
Option 1	7U Rack Mount w/Slides Only	407389
Option 2	7U Rack Mount w/Slides and Door	407390
Option 3	7U Rack Mount w/Door	407391
Option 4	7U Rack Mount (Ears Only)	407392
Option 6	Completes Slide Kit	407690-001
Option 11	9U Rack Mount w/Slides Only	407393
Option 12	9U Rack Mount w/Slides and Door	407394
Option 13	9U Rack Mount w/Door	407395
Option 14	9U Rack Mount (Ears Only)	407396
Option 16	Complete Slide Kit	407690
Option 21	1U Cable Tray (9U)	OPT 407397
Option 22	2U Cable Tray (9U)	OPT 407398
Option 23	Application Specific Front Panel (AFSP) (9U)	407399
Option 41	EMS Retrofit Kit	407400
Option 51	Backplane w/Connector Shrouds Installed	OPT 407418
Option 52	Inter-Module Mainframe Shield Kit	407419
Option 54-1	Front Extension Mount Assembly For installing 1261B in 24" Rack (7U) See Figure A-5	OPT 407431
Option 54-2	Front Extension Mount Assembly For installing 1261B in 24" Rack (9U) See Figure A-6	OPT 407421
Option 71	230 Volt Option	407401

This page was left intentionally blank.

CONFIGURING THE 1261B

Using This Chapter

This section includes procedures to install and configure the 1261B mainframe. Use this chapter to:

- Review installation site considerations.
- Install VXI modules, card guide covers, or optional blanking plates.
- Install the 1261B rack mount options, and install the mainframe into an instrument rack.
- Connect safety ground.
- Re-configure fan speed range (HI - LO) setting.
- Configure and connect to the optional Enhanced Monitoring System (EMS) module.

AC Mains Power

The 1261B AC input is both auto-voltage and auto-frequency ranging, and requires no voltage switch selection.

When the standard 1261B is shipped, it is configured for 120 VAC operation. If Option 71 (P/N 407401) is ordered, the 1261B is configured for 230 VAC operation. Should it be necessary to replace the AC mains fuse (F400), refer to Chapter 7 **Removal and Replacement of The AC Mains Fuse**.

WARNING

For your protection from electrical shock when operating at mains frequencies greater than 63Hz, connect the chassis safety ground terminal to permanent earth ground. See Figure 2-11.

Site Considerations

The 1261B Mainframe is designed to operate on a bench or in an instrument rack. If the bench top model is installed in a rack, allow 1.75 inches of clearance above the unit to permit the free flow of air through the exhaust vents in the top cover. Refer to **Figures 1-5** and **1-6** for vent locations for the 1261B bench top and rack mount mainframe, respectively. Determine how you will use your

1261B (bench or rack mount) and follow the appropriate installation instructions.

Installing VXI Modules

Install C-size modules directly into the mainframe by first placing the module's card edges into the front module guides (top and bottom). Slide the module to the rear of the mainframe until the module connectors mate solidly with the backplane connectors. Secure the module's front panel to the mainframe using the module's front panel mounting screws.

The easiest way to install B-size modules is with a "B to C-size adapter" allowing a B-size module to be installed just like a C-size.

Installation and Removal of Card Guide Covers (Airflow Directors)

In order to improve cooling of used slots in the VXI mainframe, a limited number of airflow directors, P/N 456271, may be installed at empty slot locations to redirect otherwise wasted airflow.

CAUTION

To maintain a balanced airflow throughout the system when using airflow directors, do not cover more than six empty slots at any time. If module density is low, space airflow directors evenly across the mainframe.

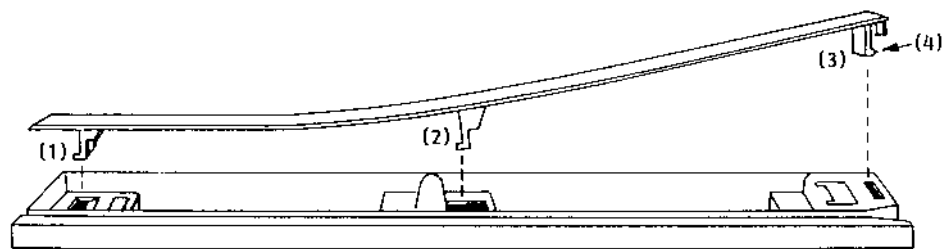

Mainframe Rear

Mainframe Front

Figure 2-1, Airflow Directors

1. Facing the front of the VXI mainframe, with one hand hold the airflow director by the front end where the "Racal" logo appears.
2. Select the slot to be covered by the director, and place the hook at the rear of the director into the rectangular hole at the rear of the cardguide (1). Slight downward pressure on top of the director (with the other hand) at the rear may be required to engage the hook into the cardguide.

3. Slightly flex the director upwards at the front, maintaining pressure at the rear, and lower the center hook of the director into the center rectangular hole in the cardguide (2).
4. Press down and back to allow both center and rear hook to engage fully into the cardguide.
5. Lower the front of the director and allow the snap-in hook to rest on the cardguide (3).
6. With a slotted screwdriver or similar flat-bladed tool, depress the spring hook (4) at a slight downward angle, applying light pressure to the logo area. This will cause the snap-hook to firmly seat the director into place.
7. To remove the airflow director, depress the snap-in hook (4) from the front with a flat-bladed tool. This will unlatch the hook and allow removal from the cardguide at the front end.
8. Pull forward to release the fixed hooks at the center and rear.

Installing Blanking Panels

In order to optimize module cooling performance, install optional blank panels (P/N 404836) into unused or empty slots. Secure with two captive mounting screws. Refer to **Figure 2-2**.

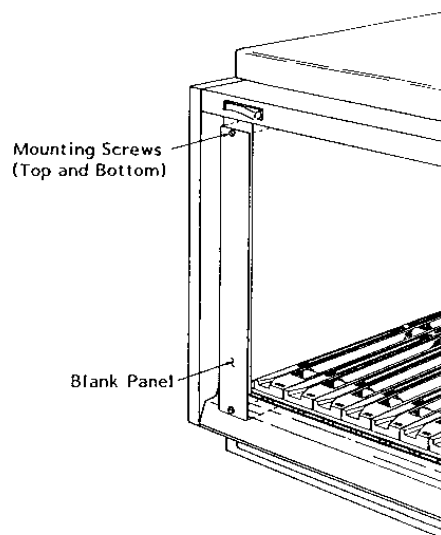

Figure 2-2, Blanking Panels

Installing The Rack Mount Options

First, perform the procedure **Installing The Slides Into The Rack**, provided below, when installing:

- Option 01 7U Rack Mount w/Slides Only
- Option 02 7U Rack Mount w/Slides & Door
- Option 11 9U Rack Mount w/Slides Only
- Option 12 9U Rack Mount w/Slides & Door

Next, perform the procedure **Preparing The Mainframe For Rack Mounting** when installing:

- All Rack Mount Options

Finally, perform procedure **Installing The Mainframe Into The Rack** when installing:

- All rack Mount Options

Reference **Figures 2-3, 2-4, 2-5** and **Table 2-1** while performing the installation of the rack mount kits.

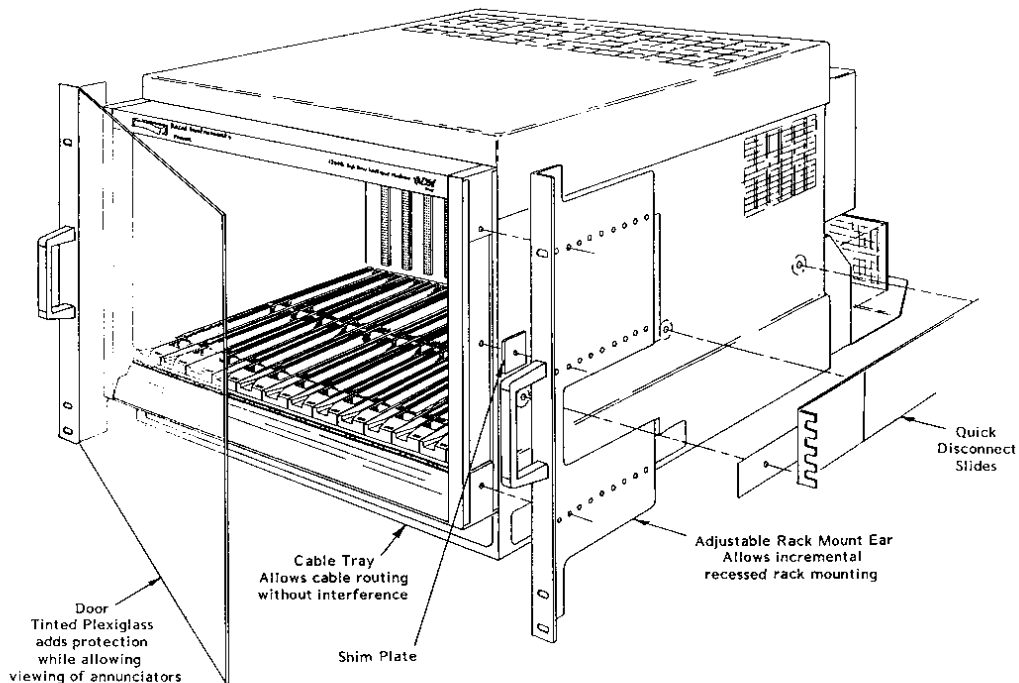

Figure 2-3, Rack Mount Options Major Components

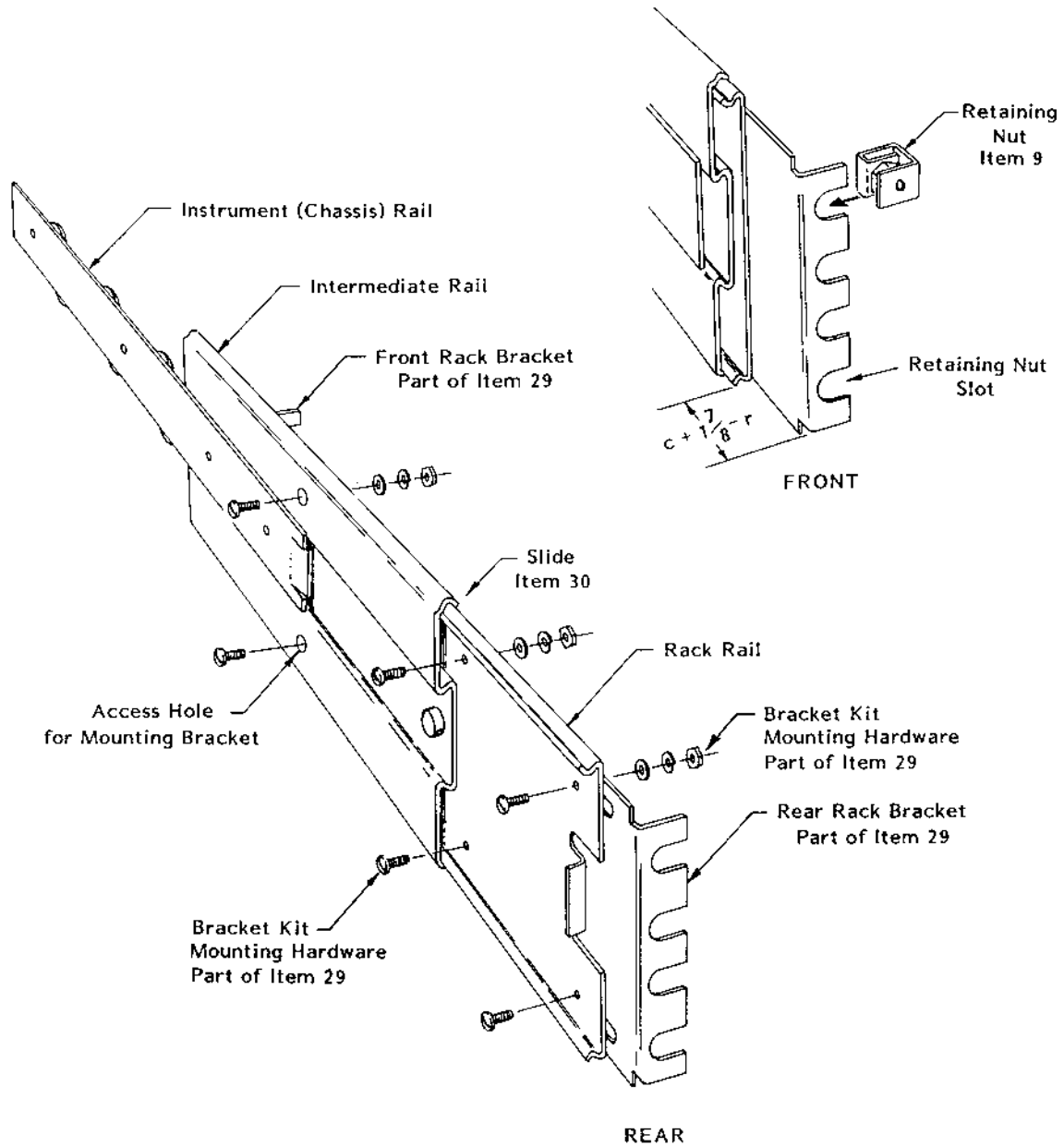

Figure 2-4, Slide and Bracket Components(9U Rack Mount Mainframe)

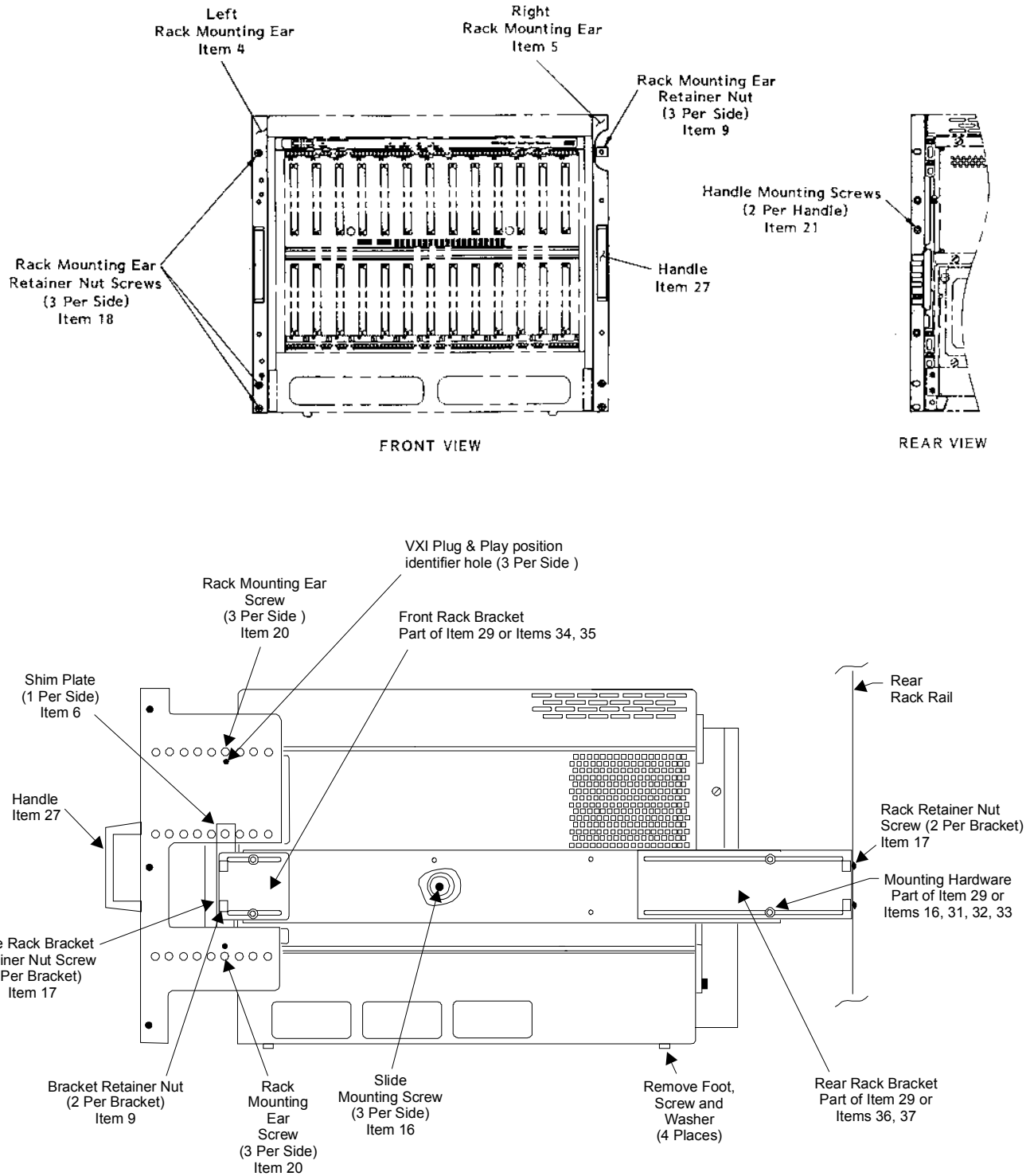

Figure 2-5, Preparing The Mainframe For Rack Mounting

Table 2-1 Rack Mount Components

ITEM	DESCRIPTION	QTY 9U	PART NUMBER 9U	QTY 7U	PART NUMBER 7U
2	Front Door Assembly	1	407403	1	407403-001
4	Left Rack Mount Ear	1	456387-001	1	456418-001
5	Right Rack Mount Ear	1	456387-002	1	456418-002
6	Rack Mount Shim Plate	2	456424	2	456424
9	Nut Retainer	14	610920	14	610920
16	Phillips Panhead #10-32 x .375 screw	10	615089	18	615089
17	Phillips Panhead #10-32 x .50 screw	8	615091	8	615091
18	Phillips Panhead #10-32 x .75 screw	6	615093	6	615093
20	Phillips Flathead #8-32 x .75 screw	6	615577	6	615577
21	Phillips Flathead #10-32 x .50 screw	4	615590	4	615590
27	Rack Slide Handle	2	921275	2	921275
29	Slide Bracket Mounting Kit	1	921317	-	-
30	Quick Disconnect Slide 24 inch	2	921424	2	921424
31	Hexnut #10-32	4	617007	12	617007
32	Flat Washer #10	4	617130	12	617130
33	Lockwasher #10	4	617130	12	617130
34	Brk, Slide Mtg, Fnt LH	-	-	1	456417-001
35	Brk, Slide Mtg Fnt LH	-	-	1	456417-002
36	Brk, Slide Mtg, Rear RH	-	-	1	456420-001
37	Brk, Slide Mtg, Rear LH	-	-	1	456420-002

Note: Complete Slide Kit is 407690 for 9U and 407690-001 for 7U size chassis.

Installing The Slides Into The Rack

The assistance of a second person may be needed for the following instrument rack assembly. Secure the slide mount assembly in the designated location of the instrument rack using the procedure below.

NOTE

To insure slide bracket kits are installed correctly to the slides, it is necessary to install the rack mounting ears (Items 4 and 5) to the mainframe at the desired recess.

If the mounting rail of the instrument rack is tapped for #10-32 screws, drill out two places for each bracket using a ¼ inch diameter bit. Proceed with the assembly.

Refer to **Figures 2-3, 2-4, 2-5** and **Table 2-1**.

1. Take the 1261B mainframe and remove the button head cap screw securing plastic trim pieces at top and bottom of front side rails, both sides. Remove trim pieces and slide trim plate from both side rails.
2. Reinsert plastic trim pieces top and bottom, position rack mounting ears (Items 4 and 5) to give desired recess and secure loosely with two flat head screws (Item 20) each side, passing through the trim piece holes.
3. Insert rack mount ear shim plate (Item 6) in each side rail groove and slide up behind rack mount ear. Align hole in shim and ear and secure with flat head screw (Item 20) both sides. Tighten top and bottom screws (Item 20).

NOTE

To comply with VXI *plug&play* receiver interconnection specification for interlocking receivers using interconnect adaptors, secure the rack mount ear using the mounting holes adjacent to the identifier hole (See Figure 2-5). This results in meeting the requirement of 100.58 mm (3.960 in) from the front surface of the rack mount ear to the mounting surface of the VXI module front panel.

4. Depending on rack style (front or internal mounting rail), choose appropriate rack brackets (long or short) Item 29, for front and rear slide attachment. Attach brackets to slide

assembly using bracket kit hardware. Leave loose for final adjustment. Install #10-32 retaining nuts (Item 9) into rack bracket slots - 8 places.

5. Measure distance “c” (inches) between rear of rack mount ear and front of the mainframe. Measure distance “r” (inches) from front of front rack mounting rail to rack slide bracket mounting surface in the rack.
6. Firmly secure front slide bracket to slide at distance d from front of slide where $d = c + 1 \frac{7}{8} - r$. (Note: d may be a negative number in which case bracket is mounted behind leading edge of slide).
7. Hold the front end of the slide mount assembly behind the front “mounting” rail of the rack, while the second person holds the rear end of the assembly.
8. Lightly secure the front slide bracket to the front mounting rail using two Phillips Panhead #10-32 x $\frac{1}{2}$ screw (Item 17). Place the front slide bracket firmly against the mounting rail before seating these screws.
9. Adjust the length of the rear slide bracket so it touches the inside of the rear mounting rail. Tighten the rear bracket-to-slide assembly screws.
10. Lightly secure the rear slide bracket to the rear mounting rail using two Phillips Panhead #10-32 x $\frac{1}{2}$ screws (Item 17). Place the rear slide bracket firmly against the mounting rail before seating these screws.
11. Install the other slide mounting assembly in the same manner.
12. Set the front dimension between the two slide mount assemblies at 16-13/16 inches (+1/16,-0) and firmly secure the front brackets to the mounting rail.
13. The distance between the two slide mount assemblies at the rear bracket should also be set at 16-13/16 inches (+1/16,-0). Should a filler-plate be required to secure the slide mount assembly to the rear rack mounting rail at 16 -13/16 inches (+1/16,-0), use the dimensions given in **Figure 2-6** to determine filler-plate size. The rear rack-bracket may require adjustment to accommodate the thickness of filler-plate.
14. Firmly secure the rear rack bracket to the rear rack mounting rail (or filler-plate) using two Phillips Panhead #10-32 x $\frac{1}{2}$ screws in each bracket (Item 17).

The slides are now positioned to accept the mainframe.

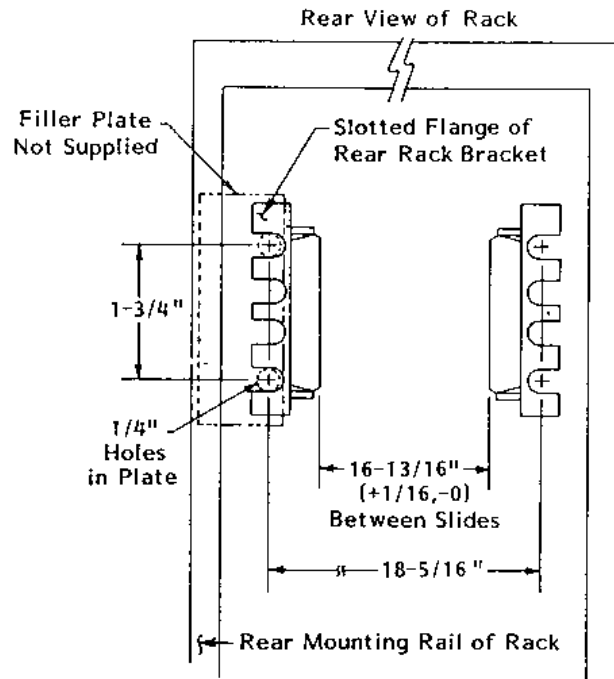

Figure 2-6, Rear End Slide Mount Rack Dimension

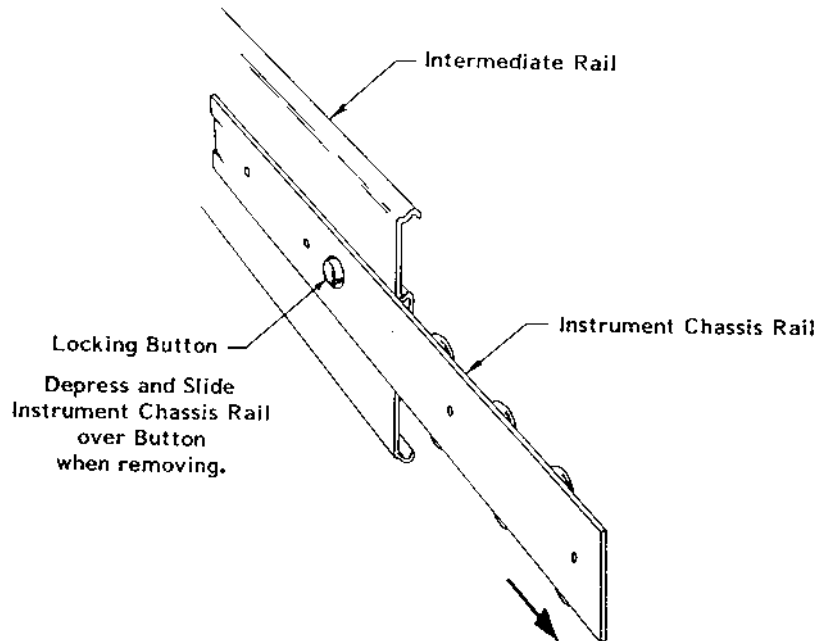

Figure 2-7, Instrument Rail Removal

Preparing The Mainframe For Rack Mounting (Omit steps 4 and 5 for options without slides)

Complete the steps below while referring to **Figures 2-3, 2-4, 2-5** and **Table 2-1**.

1. Secure rack mount ears (Items 4 and 5) to the mainframe. See **Installing The Slides Into The Rack**, Items 1, 2 and 3.
2. Install handles (Item 27) onto rack mount ears (Items 4,5) with screws (Item 21).
3. Remove bottom feet, screws and washer - four places.
4. Remove plastic rivets (3 per side) at slide mount screw hole locations (Item 16).
5. Remove the instrument (mainframe) rail from slide assemblies installed in rack. This is easily done by first extending the instrument rail out until it locks in the open position as shown in **Figure 2-7**. Depress the locking button and hold it in to unlock the rail. Slide the rail over the button and completely out of the slide mount assembly.

Mount the instrument (chassis) rails to the mainframe left and right hand side panels using screws (Item 16).

Installing The Mainframe into The Rack (Omit step 1 for options without slides)

Assistance of a second person or a mechanical lift will be needed to align and engage the mainframe with the slide assemblies in the rack.

NOTE

If slides are not used to mount the mainframe in the rack, right angle runners or a base plate MUST be used to support the mainframe.

CAUTION

DO NOT attempt to support the mainframe in the rack with the rack mount ear only.

1. Install the mainframe with its two attached instrument rails onto the quick disconnect slide mount assemblies (installed in the instrument rack). Be sure the mainframe is properly aligned and square with the slide assemblies. Remember to depress the locking buttons when inserting the instrument rails into the slide mount assemblies. When properly installed, the instrument should slide freely on the slide rails. If binding occurs, slide bracket-to-rack rail mounting screw should be loosened and re-adjusted to relieve binding.

2. The following assembly is required to lock the instrument into its operating position in the rack: (each side)
 - a. If rack rail is not tapped, slip three self-anchoring #10-32 retaining nuts (Item 9) onto the mounting rail of the rack (each side). These nuts should be aligned with the slots in the rack mounting ears previously attached to the mainframe (Items 4 and 5).
 - b. Slide the instrument fully into the rack until the rack mounting ears strike the slide screws or front rail. Secure the instrument in place using six Phillips Panhead #10-32 x 3/4 screws (Item 13).

Rack mount installation is now complete.

Installing Option 54-1 and 54-2 Receiver Front Extension

Instructions for installing Option 54-1 and 54-2 Receiver Front Extension Mount Assembly (P/N 407421 and 407431) onto the 1261B are included in the kit that is shipped with the option. See **Figures A-5** and **A-6** for side view and dimensions.

Installing Inter-Module Shields Option 52

Instructions for installing Option 52 Inter-module Shields (P/N 407419) onto the 1261B are included in the kit that is shipped with the option.

Installing ASFP Panel Option 23

Instructions for installing Option 23 ASFP Panel (P/N 407322) onto the 1261B are included in the kit that is shipped with the option.

Installing Rack Mount Door

NOTE

The door is part of Options 02, 03, 12 and 13. The door will not function if the rack mount ear is installed at the first or second row of holes behind the flange.

Refer to **Figure 2-8** and **Table 2-2** and perform the following steps to install the rack mount door.

1. Install lower halves of the two hinges (part of Item 2) to the rack mount ears with flat head screws (Item 4).
2. Install upper halves of hinges on the door with pan head screws (Item 3).
3. Install door stop (Item 5) on opposite rack mount ear with self-tapping screws (Item 6).
4. Align hole in door hinges with hinge pins on rack mount ears and mate together.
5. Latch door into place by turning latch knobs fully counter clockwise. Close door and turn knobs clockwise until door is secure.

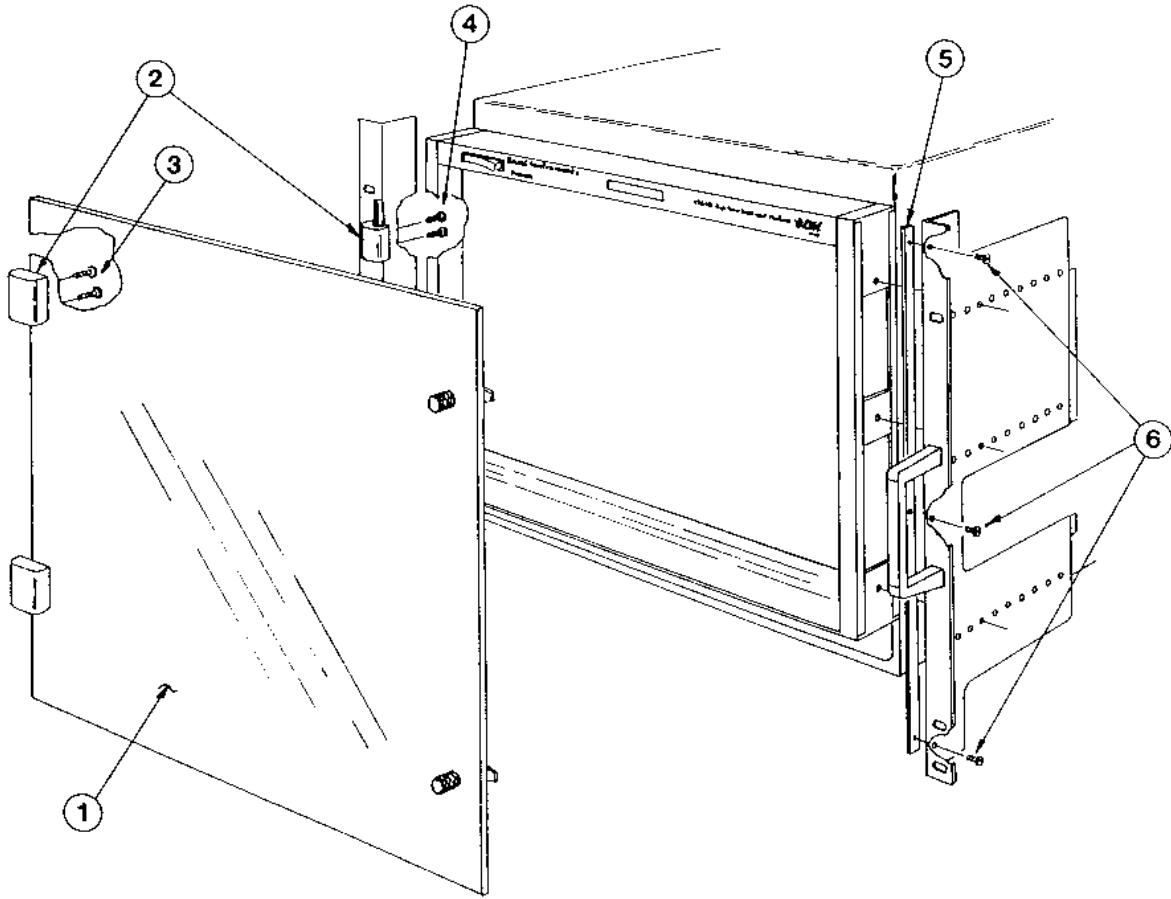

Figure 2-8, Installing Rack Door

Table 2-2, Door Components

ITEM	DESCRIPTION	QTY	9U P/N (Shown)	7U P/N
1	Door Assembly	1	407430	407429
2	Hinge, Black Nylon	2	921161	921161
3	Screw, PPH, 10-24 x .500	4	611396	611396
4	Screw, PFH, 10-24 x .500	4	611238	611238
5	Bar, Door Stop	1	456416-002	456416-001
6	Screw, PFH, 6-20 x .312	3	616482	616482

Connecting Safety Ground

Omit this procedure if you do not intend to operate the 1261B at frequencies greater than 63Hz. When operating the 1261B at mains frequencies between 47 Hz and 63 Hz, use the Chassis (Safety) Ground connection to connect the grounds of one or more instruments to the mainframe. This ensures a common ground connection between instruments.

NOTE

For your protection from electrical shock when operating at mains frequencies greater than 63Hz, connect the chassis safety ground terminal to permanent earth ground. See Figure 2-11.

1. Connect a 16 AWG (1.3mm² or larger) wire to the 8-32 chassis (safety) grounding screw using a toothed grounding lug. The wire insulation must be green with a yellow stripe or non-insulated (bare).

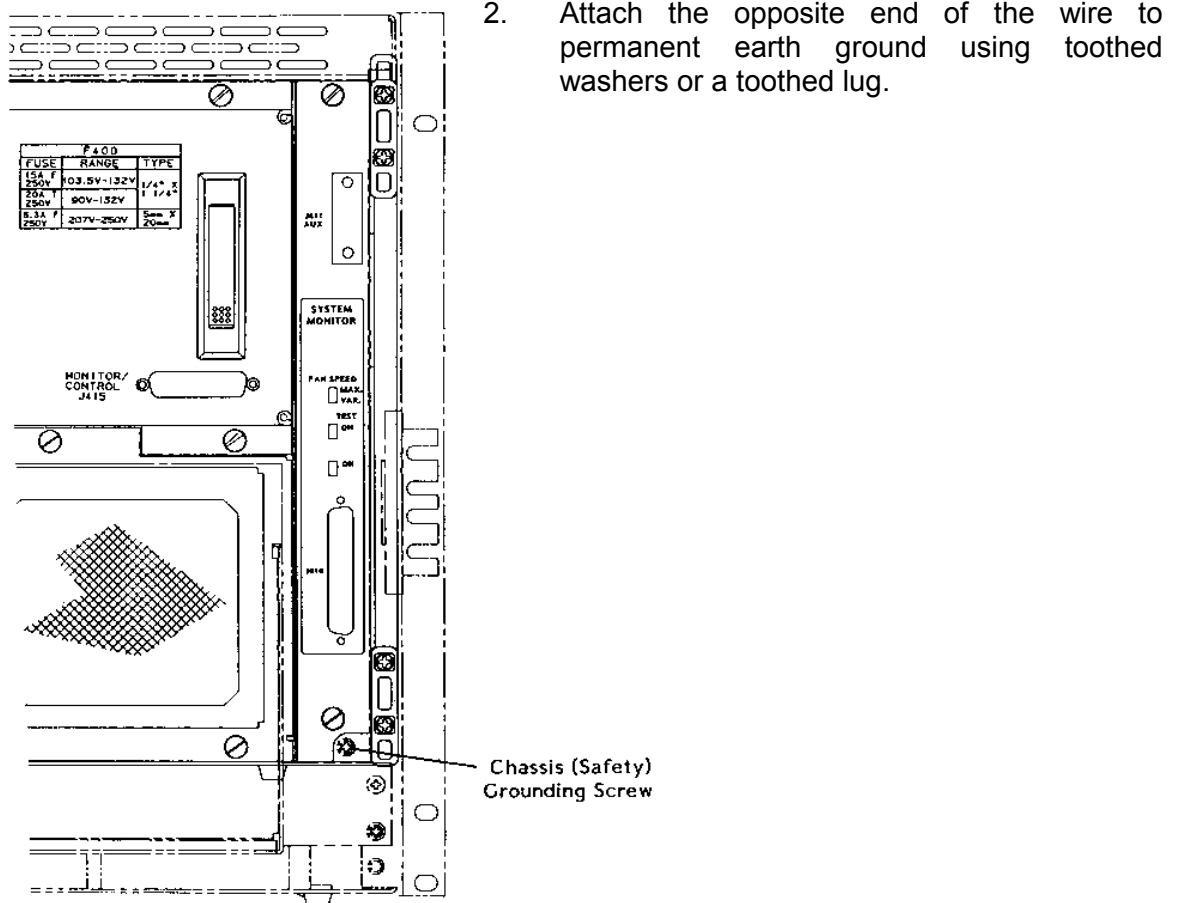

Figure 2-9, Connecting Safety Ground

Fan Speed Range (HI - LO) Selection (For Models With System Monitor)

The 1261B is shipped with the fan speed range configured to the HI setting for rack mount (or High Speed Fan) models, and to the LO setting for bench top (or Low Noise Fan) models. If your application requires more cooling or lower acoustic noise levels you may re-configure the fan speed range as described below, and in **Figure 2-10 Fan Speed Range (HI -LO) Selection**.

1. Remove SMS or EMS module. See Removal and Replacement in Chapter 7.
2. Position the jumper at J14 between pins 1-2 for the LO setting, or between pins 2-3 for the HI setting.
3. Replace the SMS or EMS module. See Removal and Replacement in Chapter 7.

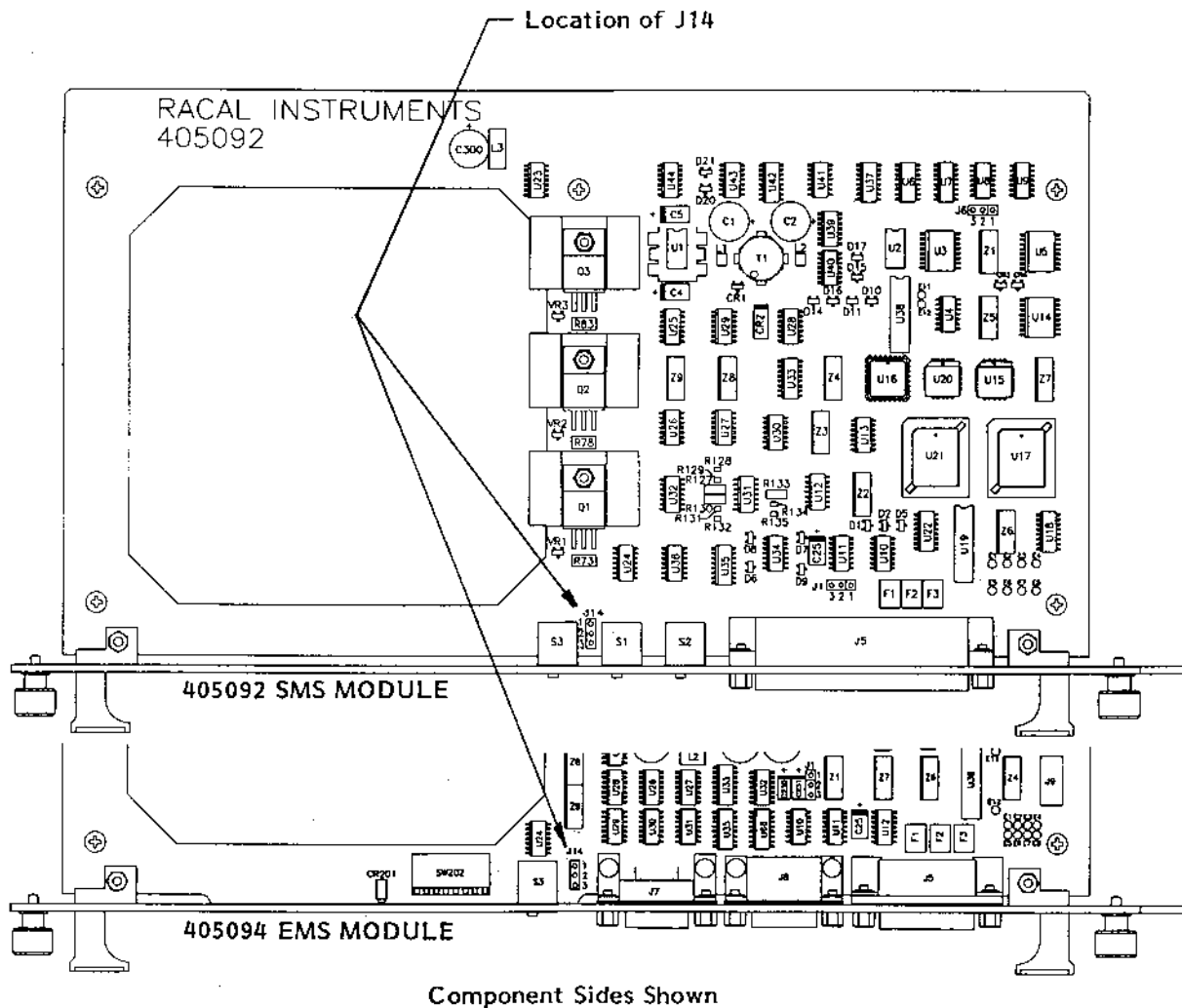

Figure 2-10, Fan Speed Range (HI -LO) Selection

Installing the Enhanced Monitoring System (EMS)

Omit the following procedures if your mainframe is not equipped with the Enhanced Monitoring System (EMS).

Enhanced Monitor VXI Logical Address Switch

The EMS module is a statically configurable SC device as described in VXIbus Specification 1.4, Sections C.2.1.1.1 and F.1. When the 1261B is shipped with the EMS, the VXI Logical Address is set to address 13 decimal. Refer to **Figure 2-11** to change the logical address of the EMS module.

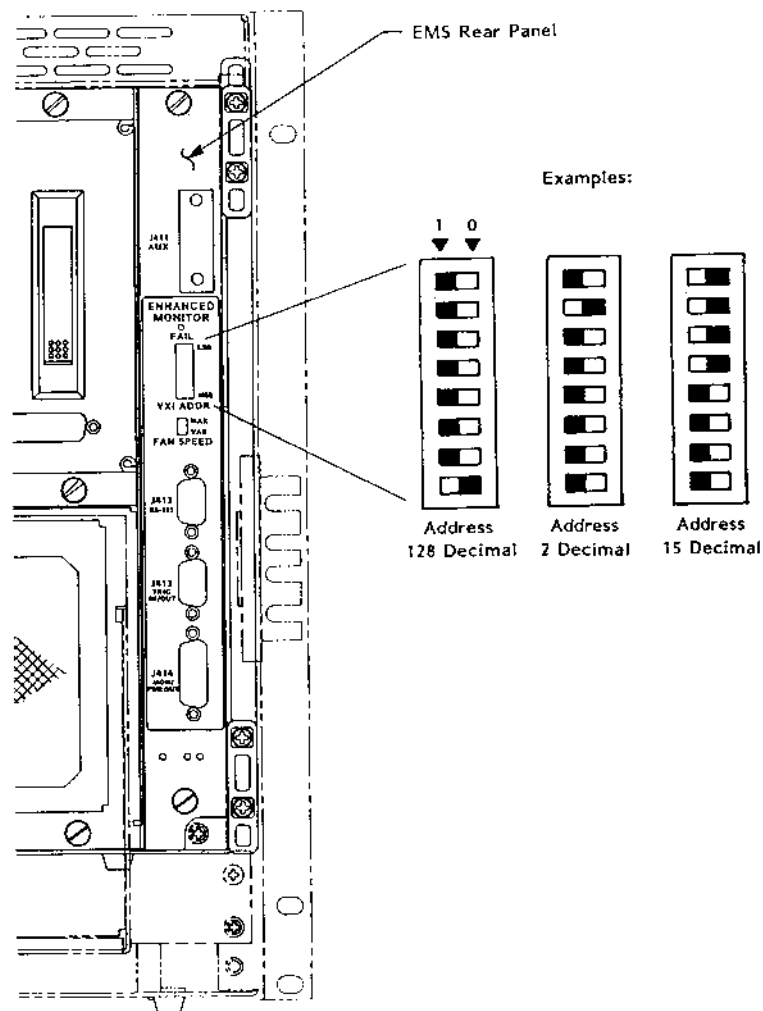

Figure 2-11, Setting The Enhanced Monitor VXI Logical Address

Enhanced Monitor Configuration Switch

Omit this procedure if your mainframe is not equipped with the Enhanced Monitoring System (EMS).

NOTE

Perform this procedure only if factory default setting is incompatible with your application. See Figure 2-12 for default setting.

WARNING

Ensure that J400 AC Input is disconnected before removing or replacing the System Monitoring (EMS) module. Possible damage to the module could result.

1. Remove the EMS module. See Removal and Replacement in Chapter 7. Position "1" enables changes.
2. Configure SW1 located on the component side of the EMS module.
3. Replace the EMS module. See Removal and Replacement in Chapter 7

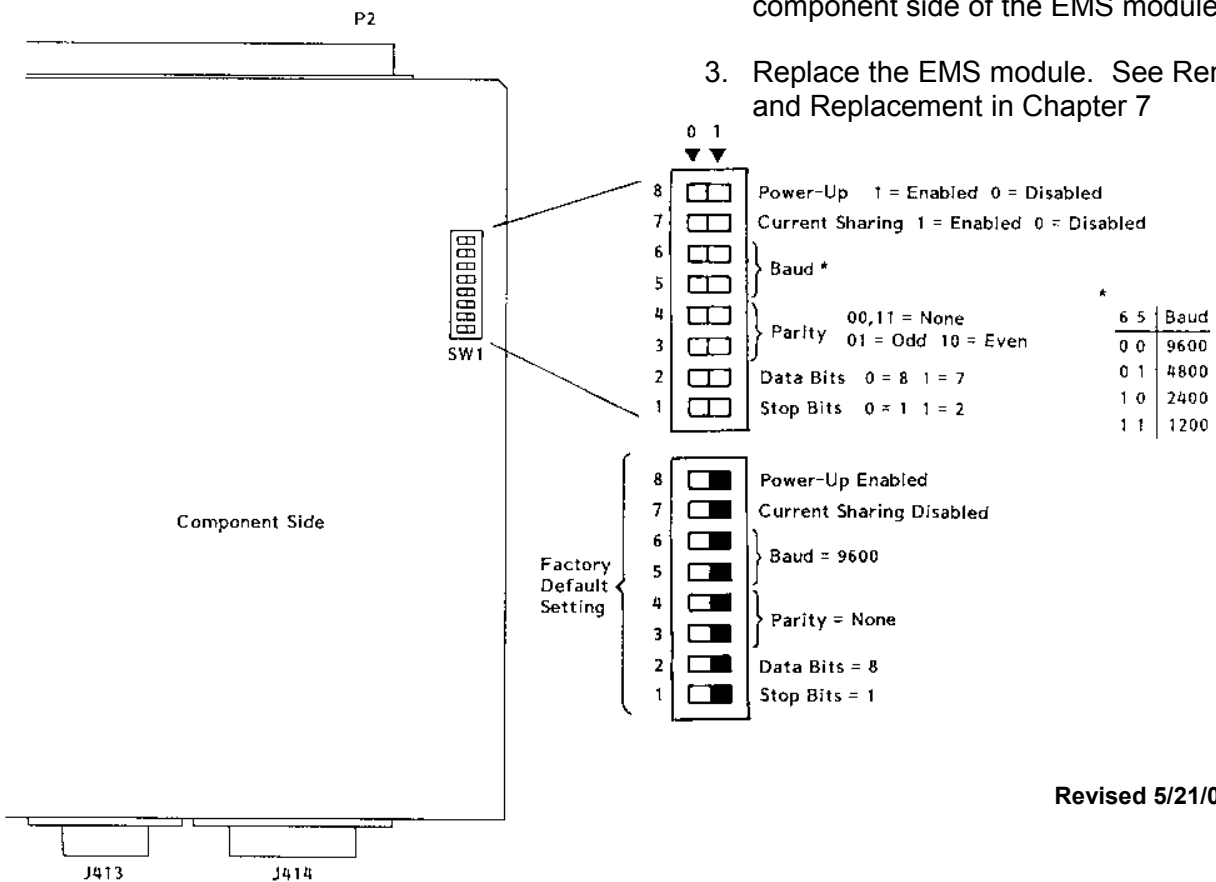

Revised 5/21/01

Figure 2-12, Setting the Enhanced Monitoring System Configuration Switch

Connecting The RS-232 Interface

Omit this procedure if your mainframe is not equipped with the Enhanced Monitoring System (EMS).

The 1261B EMS RS-232 port may be connected to a computer, data terminal, or modem. Note that the RS-232 connector on the 1261B is a female, DB-09. If you do not intend to use the RS-232 port, omit this procedure.

Connecting To a Computer, Data Terminal, or Modem

Use an RS-232 cable to connect J412 (9-pin female RS-232 connector) on the EMS rear panel to the RS-232 serial port on the host controller. Refer to **Figure 2-13 Setting Up the Enhanced Monitoring System (EMS) RS-232 Interface**, and to **Figure 2-14 RS-232 Cable Connections With a Computer, Data Terminal, or modem**.

RS-232 Flow Control Method

Flow control is a means by which the host computer (or other controller) may pace the flow of data coming from the 1261B EMS Monitor so that the host controller has time to properly receive the data. It also allows the 1261B EMS Monitor to pace commands coming from the host computer so that the 1261B EMS Monitor has sufficient time to execute the commands as they arrive.

The 1261B EMS RS-232 interface uses only "Software" flow control or "XON/XOFF". The host controller RS-232 flow control must be set for "Software" or "XON/XOFF".

With software flow control, as implemented in the 1261B EMS Monitor, an RS-232 device that is receiving data may send an XOFF character (ASCII 19₁₀) to the sending device, commanding the sending device to suspend data output. Later, when the receiving device is ready for more data, it may send an XON character (ASCII 17₁₀) to the sending device, indicating that data transmission may be resumed.

If your controller does not support flow control, it will not send or respond to XON or XOFF characters and flow control will thus be non-existent. Note that operating without flow control may necessitate a slower baud rate in order to avoid data overrun problems.

RS-232 Echo Back Considerations

The 1261B EMS Monitor will not echo back characters it receives from the terminal. If you wish to see characters on your terminal as you type them, set your terminal for "Local Echo".

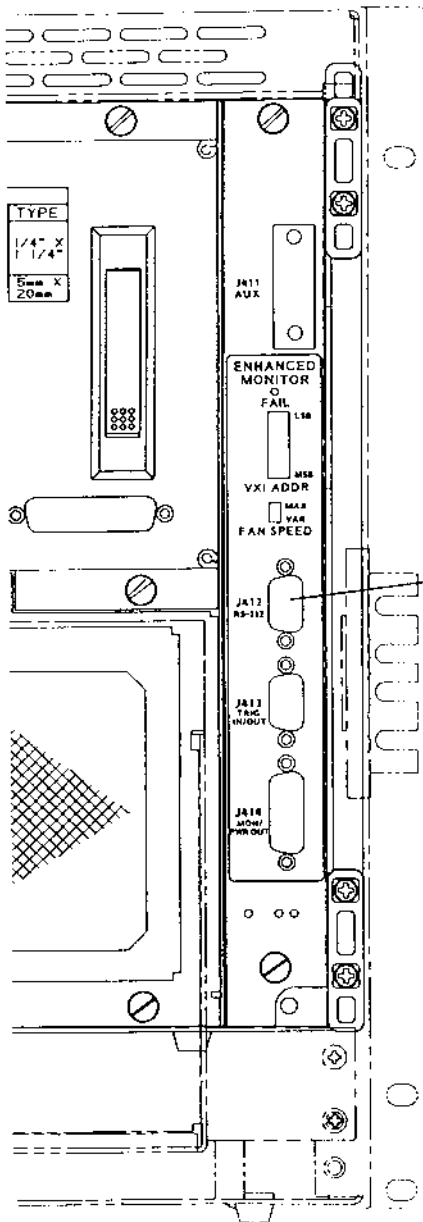

1. If factory default RS-232 setting is incompatible with your computer, (data terminal, or modem), perform the procedure described in **Figure 2-12 Setting Enhanced Monitoring System RS-232 Configuration Switch**.

The factory default setting is:

1 Stop bit, 8 data bits, No Parity, 9600 Baud, and RS-232 enabled at power on.

2. Connect host computer to RS-232 port. See **Figure 2-14 RS-232 Cable Connections With a Computer, Data Terminal, or Modem**.

RS-232 Port (J412)

J412 Pin Connections

Pin	Name
3	Received Data
2	Transmitted Data
8	Request to Send
7	Clear to Send
5	Signal Ground

Figure 2-13, Setting Up The Enhanced Monitoring System RS232 Interface

**Controlling 1261B EMS with
HyperTerminal/Win 95**

To use a P/C to control the 1261B with EMS, connect an RS-232 cable to J-412 of EMS module to the P/C. (See figure 2-16 for cable configuration.)

Run HyperTerminal Program.

C:\Accessories\HyperTerminal\HyperTrm.exe

Phone Number

Direct to Com1 or Com2

OK

Configure

Port Settings

Bits per Second 9600

Data Bits 8

Parity None

Stop Bits 1

Flow Control Xon/Off

OK

Settings

Emulation Autodetect or VT100

ASCII Setup

Send line ends with line feeds

Echo typed characters locally

ASCII Receiving

Wrap lines that exceed terminal width

OK

OK

Turn 1261B CHASSIS ON.

Response RACAL INSTRUMENTS 1261B EMS

(Check by typing *IDN?)

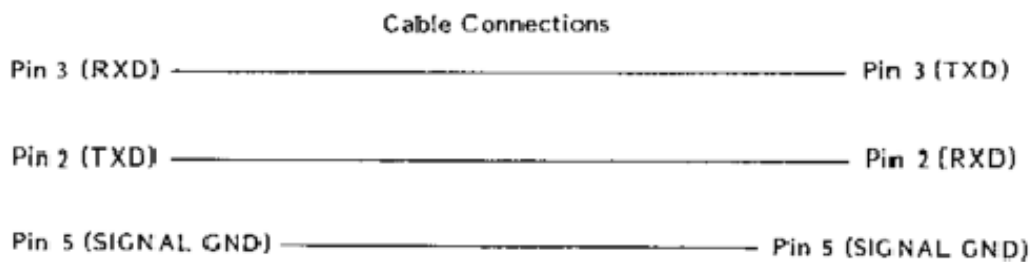
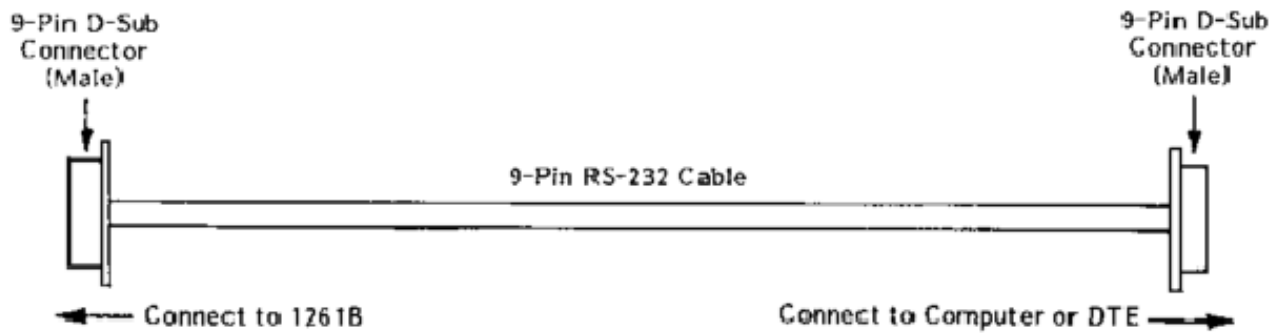

Note: This Figure applies ONLY when connecting 1261B to Data Terminal equipment, such as a Computer or DTE.

Figure 2-14, RS-232 Connections With a Computer, Data Terminal or Modem

Installing The *VXIplug&play* Software

After the EMS has been installed into the 1261B mainframe, the *VXIplug&play* software may be used to communicate with the EMS. To install the software, first power on the mainframe (see **Powering On The Mainframe** in Chapter 3), then perform the following operations:

1. Start Windows (3.1 or 3.11) on your computer if it is not already running.
2. Insert the *VXIplug&play* installation disk #1 into the 3-1/2" floppy disk drive.
3. Run the SETUP program on the installation disk.
4. Follow the instructions presented by the SETUP program.

After the SETUP program has completed, the executable Soft Front Panel program may be run. To run the Soft Front Panel, ensure that the following conditions are met:

1. The computer is connected to the 1261B VXI mainframe via a MXI/VXI interface, a GPIB/VXI interface, or the computer is an embedded VXI computer.
2. VISA is loaded onto your system. VISA is a library of functions which provide communication between a computer and instruments (GPIB and VXI). VISA may be obtained from the manufacturer of the MXI/VXI, GPIB/VXI, or embedded computer.
3. The 1261B mainframe has power applied and the power switch has been turned ON.
4. For the MXI/VXI and embedded computers, the resource manager program has been run since the 1261B mainframe power was last turned ON.

To run the Soft Front Panel, "double-click" on the 1261B EMS Front Panel" icon in the "VXIPNP" Windows Group.

If the four conditions above are met, the Soft Front Panel program will automatically locate the EMS in the 1261B Mainframe. The Soft Front Panel program will display the VXI logical address of the EMS, and the "Active" LED on the Soft Front Panel will be green.

This page was left intentionally blank.

Chapter 3

OPERATING THE 1261B

Using This Chapter

Use this Chapter to:

- Review front and rear panel controls and indicators.
- Power the mainframe on/off using the front panel switch.
- Power the mainframe on/off using the remote inhibit rear panel input.
- Power the mainframe on/off when the Current Sharing Supply Option 53 is connected to the 1261B.
- Review **Monitoring Basics** guide to front panel visual system health status.
- Perform basic functional check of the mainframe VXI voltages.
- Review Rear Panel Switch and Connector Reference for pinouts and descriptions of all rear panel connectors.

Front Panel When Equipped With Standard Monitoring System

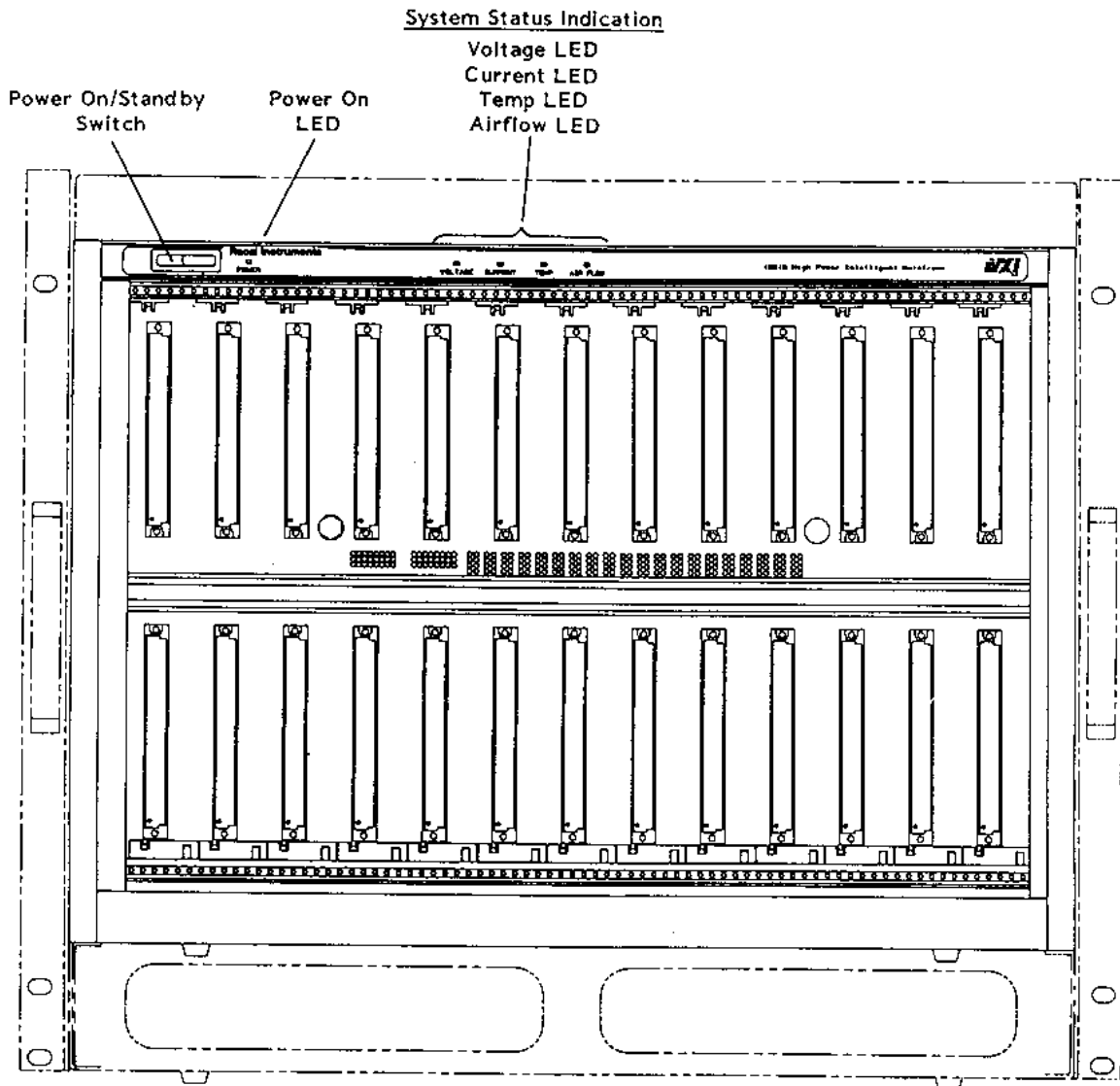

Figure 3-1, 1261B Front View With Standard Monitor

Rear Panel When Equipped With Standard Monitoring System

See **Rear Panel Switch and Connector Descriptions** (later in this Chapter) for information on rear panel features.

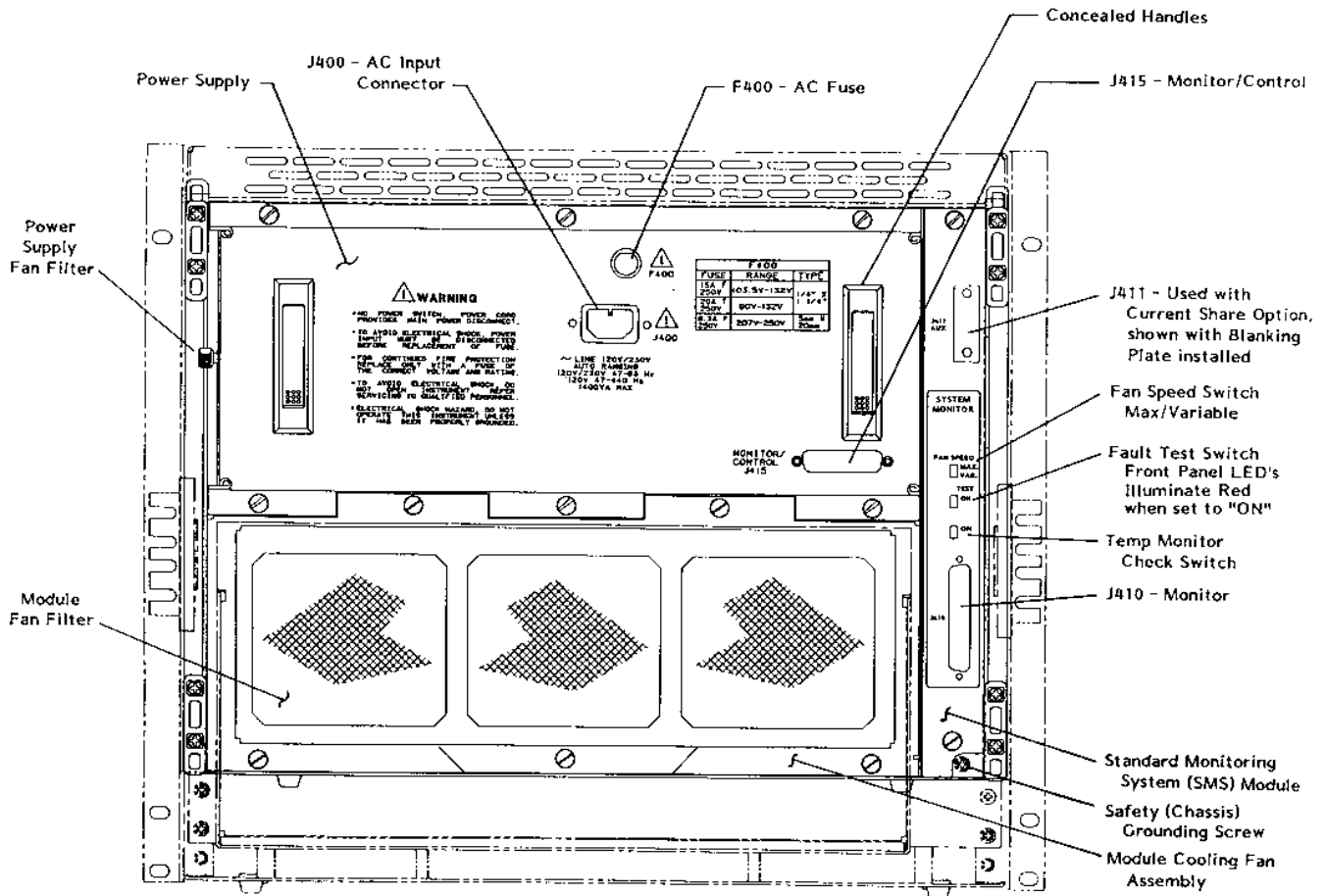

Figure 3-2, 1261B Rear View with Standard Monitor

Front Panel When Equipped With Enhanced Monitoring System

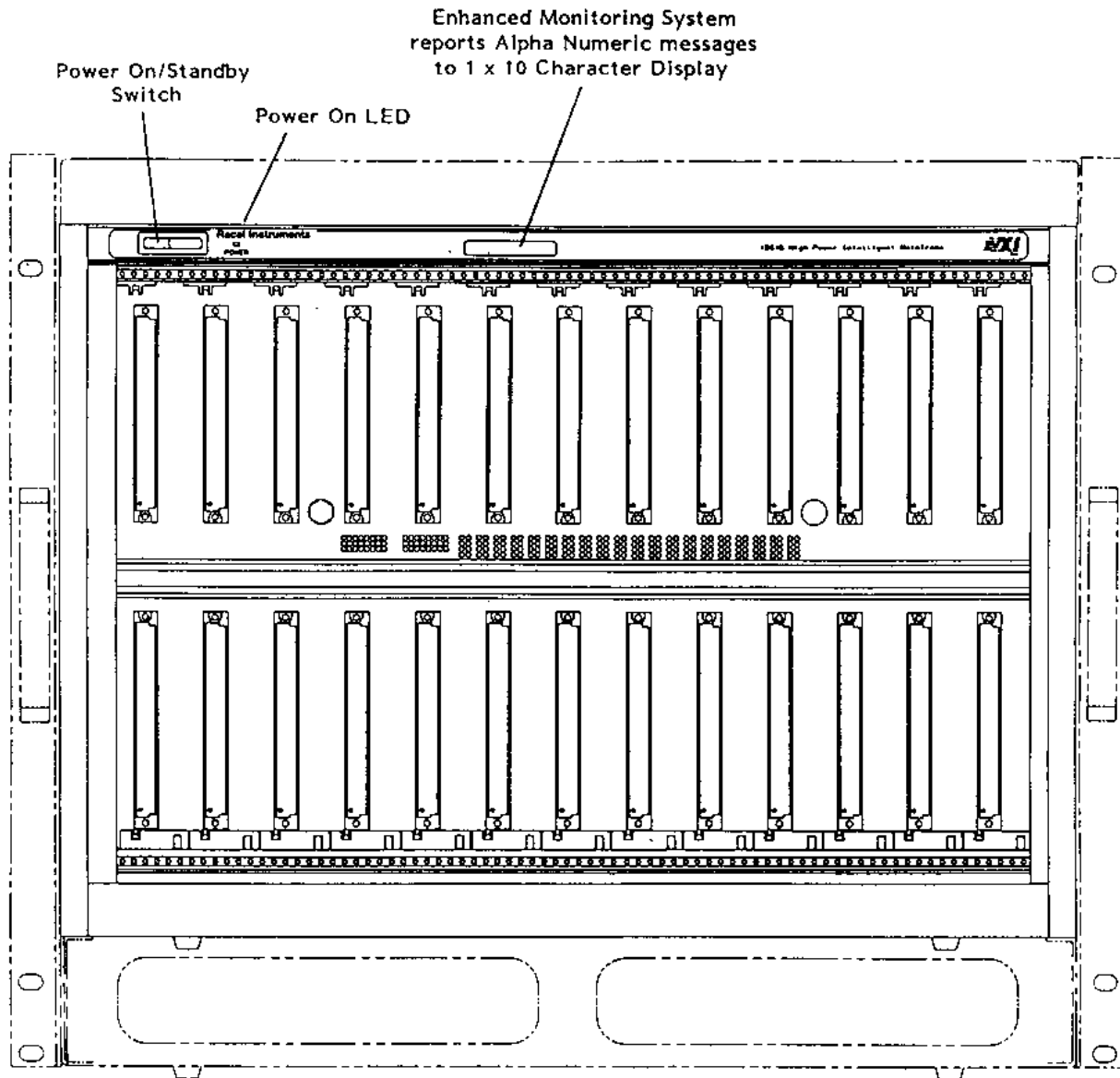

Figure 3-3, Front View With Enhanced Monitor

Rear Panel When Equipped With Enhanced Monitoring System

See **Rear Panel Switch and Connector Descriptions** (later in this chapter) and **Figure 3-4** for information on rear panel features.

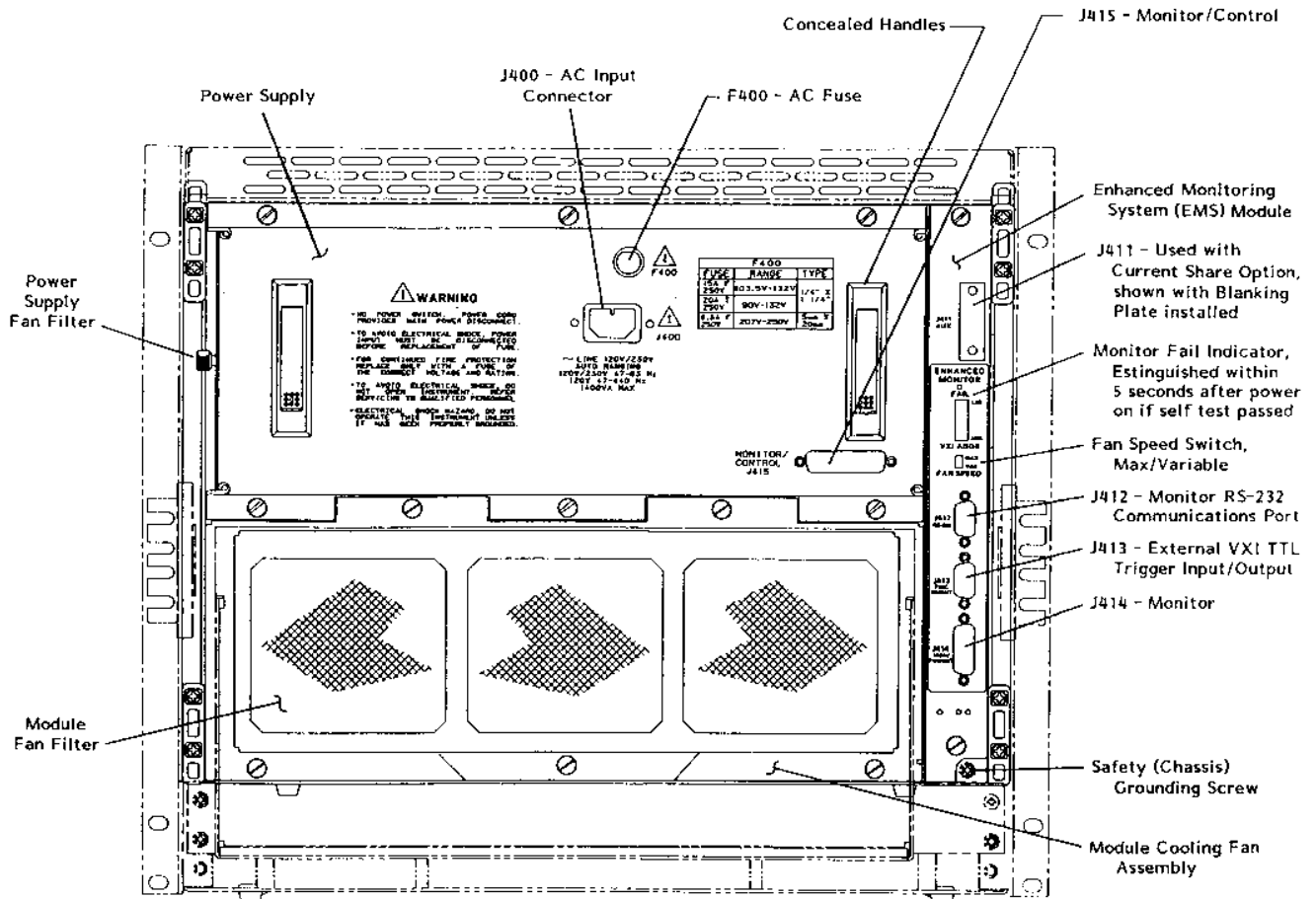

Figure 3-4, Rear View With Enhanced Monitor

Powering On The Mainframe

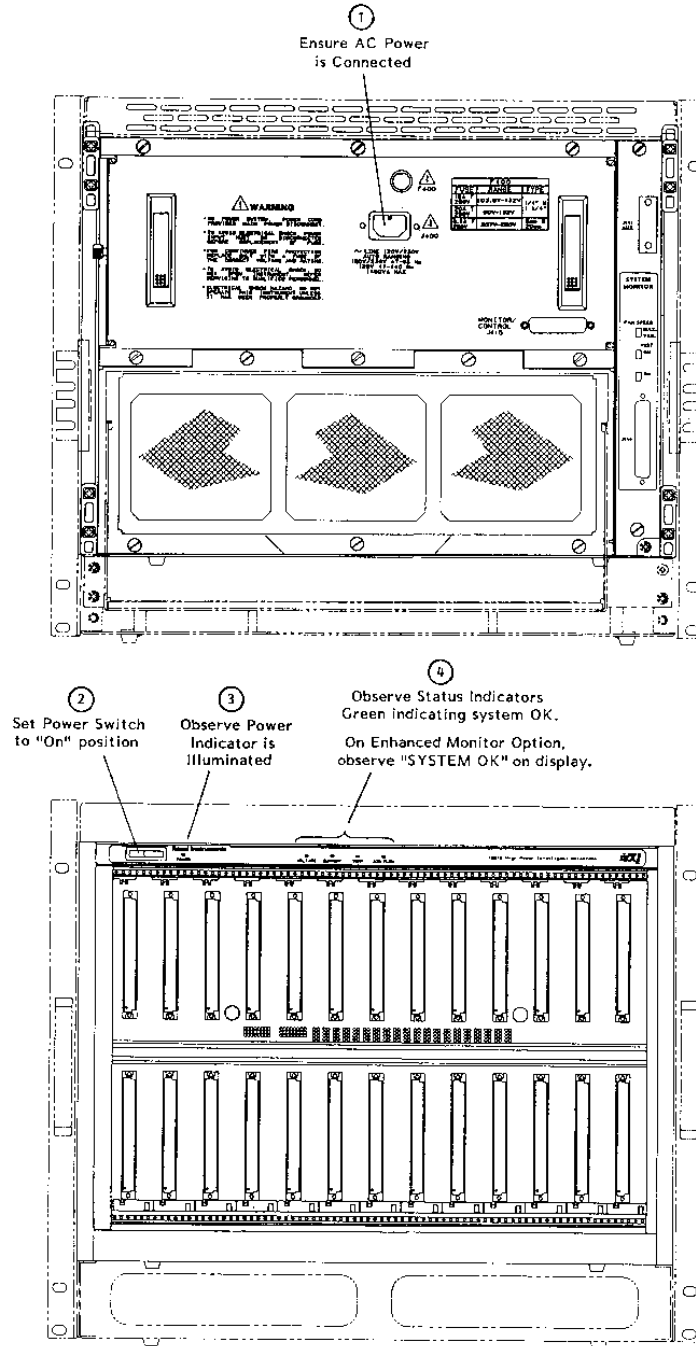
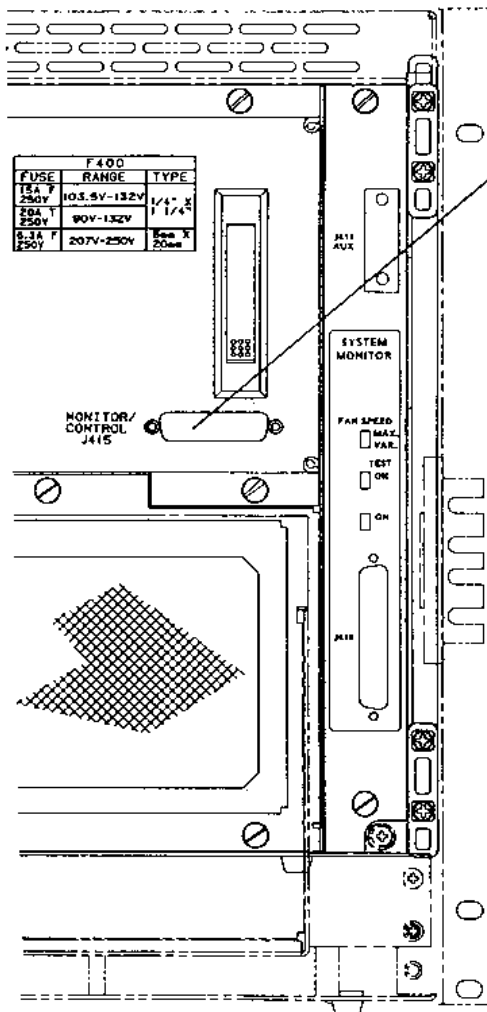

Figure 3-5, Powering On The Mainframe

Using Remote Power On/Standby Switching



Pin	Function
23	Remote INHIBIT*
2,4,14 or 24	Logic Ground (GND)

1. Connect a user supplied cable (or equivalent) between J415 (female 25 DSUB) and a remote switch, or open collector driver. The switch (or driver) should connect to J415 pin 23 (INHIBIT*) and to one of the GND pins.
2. Complete Steps in Figure 3-5 Powering On The Mainframe.
3. Place in **Standby**, DC power to mainframe **off**, by closing remote switch shorting pin J415-23 to Logic Ground (INHIBIT* to GND) or by driving J415-23 to a TTL low with an open collector driver which can sink 10mA of current.
4. Opening the remote switch (or deasserting the open collector driver) re-applies DC power to the mainframe (**Power On**) provided the front power switch is in the **on** position.

Figure 3-6, Using Remote Power On/Standby Switching

Monitoring Basics

Refer to **Figures 3-1 to 3-4** while using **Table 3-1** to interpret system monitor information. This section applies to basic features common to the Standard (SMS) and Enhanced (EMS) Monitoring Systems. See **Section 4 Using The Enhanced Monitor** for additional EMS capabilities. Refer to Section 7 **Troubleshooting** if a LED indicator or display message in the **“What You See On The Front Panel”** column is other than the color Green or the message “System OK”.

Table 3-1, Monitoring Basics

WHAT YOU SEE ON THE FRONT PANEL	WHAT IT MEANS	WHERE TO VERIFY
Voltage LED Green or “System OK”	<ul style="list-style-type: none"> • VXi Voltages are within acceptable limits <ul style="list-style-type: none"> +4.56V ≤ +5V Rail ≤ +5.50V +10.95V ≤ +12V Rail ≤ +13.20V +21.90V ≤ +24V Rail ≤ +26.40V -2.20V ≤ -2V Rail ≤ -1.83V -5.72V ≤ -5.2V Rail ≤ -4.75V -13.20V ≤ -12V Rail ≤ -10.95V -26.40V ≤ -24V Rail ≤ -21.90V 	<ul style="list-style-type: none"> • At rear panel connector J415 <ul style="list-style-type: none"> J415 Pin 11 J415 Pin 17 J415 Pin 16 J415 Pin 3 J415 Pin 8 J415 Pin 15 J415 Pin 1 <p>Use J415 Pin 2, 4, 14, or 24 as Ground reference.</p>
Current LED Green or “System OK”	<ul style="list-style-type: none"> • Current draw from each of the seven VXi voltage supplies is ≤ 100% of the rated value <ul style="list-style-type: none"> +5V Rail ≤ 80Amps +12V Rail ≤ 17Amps +24V Rail ≤ 12Amps -2V Rail ≤ 30Amps -5.2V Rail ≤ 60Amps -12V Rail ≤ 17Amps -24V Rail ≤ 12Amps 	<ul style="list-style-type: none"> • At rear panel connector J415. These signals are scaled such that 0V reading = 0% full rated current, and 5V = 100% full rated current. <ul style="list-style-type: none"> J415 Pin 21 J415 Pin 18 J415 Pin 5 J415 Pin 7 J415 Pin 20 J415 Pin 6 J415 Pin 19 <p>Use J415 Pin 2, 4, 14 or 24 as Ground reference.</p>

WHAT YOU SEE ON THE FRONT PANEL	WHAT IT MEANS	WHERE TO VERIFY
Temp LED Green or "System OK"	<ul style="list-style-type: none"> • Maximum slot temperature $\leq 75^{\circ}\text{C}$ • Maximum slot temperature rise $\leq 20^{\circ}\text{C}$ 	<ul style="list-style-type: none"> • J410 Pin 4 on SMS or J414 Pin 4 on EMS. 100mV per $^{\circ}\text{C}$, 0°C corresponds to 0 V • J410 Pin 5 on SMS or J414 Pin 5 on EMS. 100mV per $^{\circ}\text{C}$, 0°C corresponds to 0 V Use J410 or J414 Pin 9 or 10 as ground reference.
Airflow LED Green or "System OK"	<ul style="list-style-type: none"> • Module cooling fans are operating above acceptable limit Fan Speed ≥ 900 RPM (SMS units) or Fan Speed ≥ 2000 RPM (EMS units) 	<ul style="list-style-type: none"> • J410 Pin 6, 7, 8 on SMS or J414 Pin 6, 7, 8 on EMS. 2 Pulses per Revolution, TTL Pulse Train Use J410 or J414 Pin 9 or 10 as ground reference

Rear Panel Switch and Connector Descriptions

Table 3-2, SMS Rear Panel Switches

Switch Reference	Description
FAULT TEST	<p>Fault Test Switch. Set this switch to the ON position to cause a fault indication on all SMS front panel health status annunciators (Voltage, Current, Temperature and Airflow).</p> <p>NOTE: This switch must be set to the OFF position to allow normal operation.</p> <p>Use this switch to perform a quick check of the SMS monitor and the front panel health status annunciators.</p>
TEMP MONITOR CHECK	<p>Temp Monitor Check Switch. Set this switch to the ON position to cause the Tmax signal output (J410 Pin 4) to indicate +33.9°C +/-2°C.</p> <p>Use a Digital Multimeter to measure the voltage between J410 Pin 4 (Tmax) and J410 Pin 9 (Logic Ground). The voltage reading should be +3.39 VDC, +/- 0.2VDC, corresponding to +33.9°C, +/- 2°C.</p> <p>NOTE: This switch must be set to the OFF position to allow normal operation.</p>
FAN SPEED	<p>Fan Speed Switch. This switch enables fan speed control when set the VAR (Variable) position. Set this switch to MAX to run fans at full speed. In the VAR position the monitoring system automatically controls the speed of the fans depending on the air temperature and the amount of cooling required by the modules.</p>

Table 3-3, EMS Rear Panel Switches

Switch Reference	Description
FAN SPEED	<p>Fan Speed Switch. This switch enables fan speed control when set the VAR (Variable) position. Set this switch to MAX to run fans at full speed. In the VAR position the monitoring system automatically controls the speed of the fans depending on the air temperature and the amount of cooling required by the modules.</p>
LOGICAL ADDRESS	<p>VXI Logical Address Switch. Refer to Chapter 2 Enhanced Monitor VXI Logical Address Switch.</p>

Table 3-4, J410 SMS Rear Panel Monitor

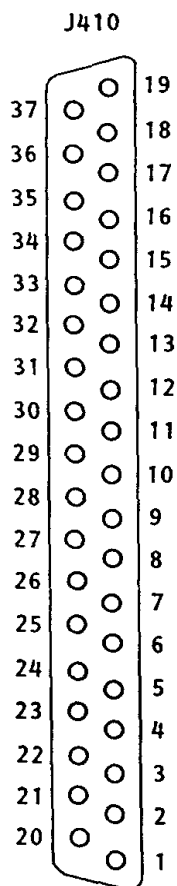

Pin	Signal	Description
1	+5V	+5 V for powering external user circuitry, etc. (1 A max.)
2	+12V	+12 V for powering external user circuitry, etc. (1 A max.)
3	+24V	+24 V for powering external user circuitry, etc. (1 A max.)
4	T_{max}	Output signal proportional to the maximum absolute temperature of the 13 modules (100 mV/°C, 0 V corresponds to 0°C)
5	ΔT	Output signal proportional to the maximum absolute temperature rise (w/ respect to internal ambient sensor) of the 13 modules (100 mV/°C, 0 V corresponds to 0°C)
6	TACH1	TTL output proportional to the speed of Fan 1 (2 pulses/ revolution)
7	TACH2	TTL output proportional to the speed of Fan 2 (2 pulses/ revolution)
8	TACH3	TTL output proportional to the speed of Fan 3 (2 pulses/ revolution)
9,10,28	GND	Logic Ground
11-27, 29-37	RSV	Reserved

Table 3-5, J412 EMS RS-232 Port

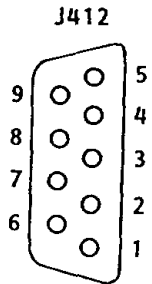

Pin	Signal	Description
2	TXDA	Transmit Data
3	RXDA	Received Data
5	GND	Logic Ground
7	CTS	Clear To Send
8	RTS	Request To Send
1,4,6,9	RSV	Reserved

Table 3-6, J413 EMS TTL Trigger Connector

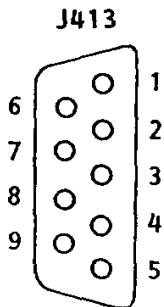

Pin	Signal	Description
1	TRIG IN	TTL level input signal which is routed to any one of the eight TTLTRIG lines on the VXI backplane, with or without a programmable delay applied.
2	TRIG OUT	TTL output signal which is routed from any one of the eight TTLTRIG lines on the VXI backplane, with or without a programmable delay applied.
6,7,8	GND	Logic Ground
3-5,9	RSV	Reserved

Table 3-7, J414 EMS Rear Panel Monitor

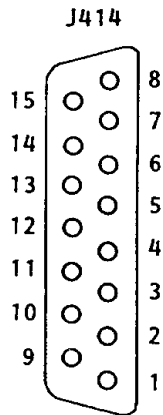

Pin	Signal	Description
1	+5V	+5V for powering external user circuitry, etc. (1 A max.)
2	+12V	+12V for powering external user circuitry, etc. (1 A max.)
3	+24V	+24V for powering external user circuitry etc. (1 A max.)
4	T _{max}	Output signal proportional to the maximum absolute temperature of the 13 modules (100 mV/°C, 0 V corresponds to 0°C)
5	Fan Speed Control	Output signal proportional to the fan speed. 0V = Minimum fan speed 1V = Maximum fan speed
6	TACH1	TTL output proportional to the speed of Fan 1 (2 pulses/revolution)
7	TACH2	TTL output proportional to the speed of Fan 2 (2 pulses/revolution)
8	TACH3	TTL output proportional to the speed of Fan 3 (2 pulses/revolution)
9-11	GND	Logic Ground
12-15	RSV	Reserved

Table 3-8, J415 Rear Panel Monitor/Control Connector

Pin	Signal	Description
1	-24 VMON	VXIbus Voltage Monitor Output
2	GND	Logic Ground
3	-2 VMON	VXIbus Voltage Monitor Output
4	GND	Logic Ground
5	+24 IMON	Power Supply Current Monitor Output
6	-12 IMON	Power Supply Current Monitor Output
7	-2 IMON	Power Supply Current Monitor Output
8	-5.2 VMON	VXIbus Voltage Monitor Output
9	RSV	Reserved
10	+5 STANDBY	VXIbus +5V Standby Input
11	+5 VMON	VXIbus Voltage Monitor Output
12	ACFAIL*	VXIbus ACFAIL* Input or Monitor Output (see note)
13	RSV	Reserved
14	GND	Logic Ground
15	-12 VMON	VXIbus Voltage Monitor Output
16	+24 VMON	VXIbus Voltage Monitor Output
17	+12 VMON	VXIbus Voltage Monitor Output
18	+12 IMON	Power Supply Current Monitor Output
19	-24 IMON	Power Supply Current Monitor Output
20	-5.2 IMON	Power Supply Current Monitor Output
21	+5 IMON	Power Supply Current Monitor Output
22	+5 STANDBY	VXIbus +5V Standby Input
23	R INHIBIT*	Power Supply Remote Inhibit Input
24	GND	Logic Ground
25	SYSRESET*	VXIbus SYSRESET* Input or Monitor Output (see note)

Note: Refer to VXIbus and VMEbus specifications for details on using the ACFAIL* and SYSRESET* signals. If you use these signals, do not violate VXIbus or VMEbus electrical specification.

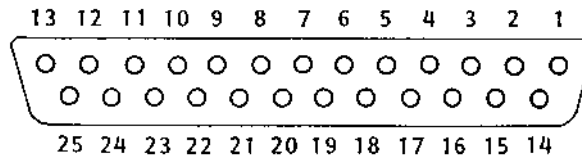

Basic Functional Check

The functional check consists of checking the 1261B power supply voltages to the VXIbus limits at rear panel connector J415 using a digital voltmeter.

Referring to **Table 3-10**, connect one lead of the voltmeter to a supply pin at J415. Connect the reference lead of the voltmeter to one of the ground pins. Compare each voltage reading to the values listed in **Tables 3-10**.

Table 3-9, Power Supply Voltages at J415

J415 Pin	Supply	VXI Acceptable Voltage Range
11	+5V	4.875V to 5.25V
15	-12V	-12.6 to 11.64V
1	-24V	-25.2V to -23.28V
3	-2V	-2.1V to -1.9V
17	+12V	11.64V to 12.6V
16	+24V	23.28V to 25.2V
8	-5.2V	-5.46V to -5.044V
2,4,14 or 24	Logic Ground	

If the voltages are within the specified ranges, the mainframe complies with VXI voltage limit specifications.

This page was left intentionally blank.

USING THE ENHANCED MONITORING SYSTEM

Overview

This chapter contains information about how to operate the Model 1261B Enhanced Monitoring System (EMS). The instrument can be programmed using a set of SCPI commands. A list of SCPI commands, implemented by the Model 1261B EMS, is given in **Table 5-1**. The following paragraphs describe the various modes of operation and give examples on how to program the Model 1261B EMS.

Power On/Reset Defaults

After executing a software reset, the EMS defaults to the conditions shown in **Table 4-1**. A complete list of all parameters and their default values is given in Chapter 5.

NOTE

When disconnecting AC power from the 1261B, such as when using a power strip, wait at least three seconds before reconnecting. This ensures that the EMS is properly reset.

Upon power-on, the EMS state will be reset to the power-on state described in **Table 4-1**. If DIP switch SW1-8 is set, the instrument state will be recalled from nonvolatile memory location 0. As shipped from the factory, nonvolatile location 0 holds the instrument state as described in **Table 4-1**. The power-on state of the EMS can be changed by overwriting the contents of nonvolatile location 0 by using the command:

*SAV 0

The command below may be used to place the instrument in its default state as described in **Table 4-1** on the following page.

*RST

Table 4-1, Default Limit Settings After Power On, *RST

Power Supply Voltage Limits:

Power Supply (PS)	Maximum	Minimum
+5V	5.25V	4.87V
-5.2V	5.04V	5.46V
-2V	-1.90V	2.10V
+24V	25.20V	23.28V
-24V	-23.28V	-25.20V
+12V	12.60V	11.64V
-12V	-11.64V	-12.60V

Power Supply Current Limit:

Power Supply (PS)	Maximum
+5V	80A
-5.2V	60A
-2V	30A
+24V	12A
-24V	12A
+12V	17A
-12V	17A

Fan Speed Limit: 2000 RPM Minimum
4999 RPM Maximum

Absolute Temperature Limit: 55°C
Ambient Temperature Limit: 55°C
Slot Temperature Rise Limit: 30.0°C
Number of VXI Bus Errors/LACKs: 0 (disabled)
Power On Time Limit: 1 year
Cumulative Power-On Time Limit: 5 years
Filter Service Time Limit: 4320 hours of power-on time (180 days)
Trigger In/Trigger Out Delay: 0.0 Seconds
TRIG IN Input: Disconnected
TRIG OUT Output: Disconnected
Front Panel Display State: On
Front Panel User Message: None
RS-232 Baud Rate: 9600 (set by DIP switch SW1)
RS-232 Parity: None (set by DIP switch SW1)
RS-232 Data Bits: 8 (set by DIP switch SW1)
RS-232 Stop Bits: 1 (set by DIP switch SW1)
Current Sharing Option 53: Disabled (set by DIP switch SW1-7)

What To Do Now

When writing commands to operate the Model 1261B EMS, follow the instructions in this chapter to understand the meaning and response that each command generates. Examples contained in the following paragraphs show basic techniques on how to program output waveforms.

Measuring Power Supply Voltages

The "MEAS:VOLT" command is used to measure the voltage presently being output by one of the seven VXI power supplies. The following commands may be used:

MEAS:VOLT1?	-- measure +5V PS Voltage
MEAS:VOLT2?	-- measure -5.2V PS Voltage
MEAS:VOLT3?	-- measure -2V PS Voltage
MEAS:VOLT4?	-- measure +24V PS Voltage
MEAS:VOLT5?	-- measure -24V PS Voltage
MEAS:VOLT6?	-- measure +12V PS Voltage
MEAS:VOLT7?	-- measure -12V PS Voltage

Each of these causes the 1261B EMS to reply with a value formatted as a real number. The number is rounded to the nearest 0.01 VDC.

Measuring Power Supply Currents

The "MEAS:CURR" command is used to measure the current presently being output by one of the seven VXI power supplies. The following commands may be used:

MEAS:CURR1?	-- measure +5V PS Current
MEAS:CURR2?	-- measure -5.2V PS Current
MEAS:CURR3?	-- measure -2V PS Current
MEAS:CURR4?	-- measure +24V PS Current
MEAS:CURR5?	-- measure -24V PS Current
MEAS:CURR6?	-- measure +12V PS Current
MEAS:CURR7?	-- measure -12V PS Current

Each of these causes the 1261B EMS to reply with a value formatted as a real number. The number is rounded to the nearest 0.1 ADC.

Measuring Ambient Temperature

The "MEAS:TEMP14" command is used to measure the ambient temperature.

MEAS:TEMP14?	-- measure ambient temperature
--------------	--------------------------------

This command causes the 1261B EMS to reply with a value formatted as a real number. The number is rounded to the nearest 1 degree Celsius.

Measuring VXI Slot Temperature

Each VXI slot temperature may be read individually. The following commands may be used to read the specified VXI slot temperature:

MEAS:TEMP1?	-- read slot 0 temperature
MEAS:TEMP2?	-- read slot 1 temperature
MEAS:TEMP3?	-- read slot 2 temperature
MEAS:TEMP4?	-- read slot 3 temperature
MEAS:TEMP5?	-- read slot 4 temperature
MEAS:TEMP6?	-- read slot 5 temperature
MEAS:TEMP7?	-- read slot 6 temperature
MEAS:TEMP8?	-- read slot 7 temperature
MEAS:TEMP9?	-- read slot 8 temperature
MEAS:TEMP10?	-- read slot 9 temperature
MEAS:TEMP11?	-- read slot 10 temperature
MEAS:TEMP12?	-- read slot 11 temperature
MEAS:TEMP13?	-- read slot 12 temperature

Each of these queries causes the 1261B EMS to reply with a value formatted as a real number. The number is rounded to the nearest 0.1 degree Celsius.

Note that the temperature rise of any slot may be computed by the difference between the ambient temperature and the slot's temperature ((MEAS:TEMPX?) - (MEAS:TEMP14?)).

Measuring Fan Speed

Each of the three fan speeds may be read individually. The following commands may be used to read the fan speed:

MEAS:FREQ1?	-- read SLOWEST fan speed
MEAS:FREQ2?	-- read Fan #1 fan speed
MEAS:FREQ3?	-- read Fan #2 fan speed
MEAS:FREQ4?	-- read Fan #3 fan speed

Each of these queries causes the 1261B EMS to reply with an integer value. The fan speed is rounded to the nearest whole number. The unit of measure is RPM (revolutions per minute).

Measuring Elapsed Time

The 1261B EMS monitors three elapsed time attributes. These are as follows:

- Power-on Time

The number of seconds since the power switch was switched from the OFF state to the ON state.

- Cumulative Power-on Time

The total number of seconds which the power switch has been in the ON state from the time the EMS was installed.

- Filter Service Time

The total number of seconds which the power switch has been in the ON state since the filter was last serviced (and the "SENSE:TIME3:CLEAR" command was executed).

The following commands may be used to read the elapsed time attributes:

```
MEAS:TIME1?      -- read power-on time
MEAS:TIME2?      -- read cumulative power-on time
MEAS:TIME3?      -- read power-on time since last
                  filter service
```

Each of these queries causes the 1261B EMS to reply with an integer value. The unit of measure is seconds.

Reading The Present State of VXI Signals

The 1261B EMS has the capability to read the present state of the VXI SYSFAIL*, ACFAIL*, and AS* (address strobe) lines. The following commands may be used to read the present state of each of these lines:

```
MEAS:VXI:ACFAIL?  -- read ACFAIL* line
MEAS:VXI:SYSFAIL? -- read SYSFAIL* line
MEAS:VXI:ASTROBE? -- read AS* line
```

Each of these queries causes the 1261B EMS to reply with a 1 if the line is high, or a 0 if the line is low. Note that since each of these lines is asserted when low, the normal reply should be "1".

Monitoring The VXI Subsystem

The 1261B EMS has the ability to monitor the VXI power supplies' voltage and current, VXI slot temperatures, fan speeds, and select VXI signals. When one of these is outside the user-specified limits, an interrupt can be generated. This allows the system controller (computer) to effectively monitor the VXI subsystem without having to continually poll the 1261B EMS.

Each attribute is checked once per second, at a minimum, by the EMS. If the attribute value is outside the programmed limits, an "alarm" condition is assumed to exist. If the EMS has been told to generate an interrupt when the alarm condition exists, an interrupt will be sent to the system controller (by asserting one of the VXI interrupt lines IRQ1 to IRQ7).

When the system controller detects the interrupt, it can read status registers on the EMS to determine which attribute is at fault. It can then query the EMS to determine the present value of the attribute. It can also query the EMS to determine the time and date of the alarm condition.

Programming the EMS to perform this monitoring is done as a two-step process:

- 1) Program the tolerance limits for the attribute
- 2) Program the status registers to generate an interrupt when the attribute is outside its tolerance limits.

Programming The Tolerance Limits

The various SENSE commands are used to set the programmable tolerance limits for the various attributes monitored by the 1261B EMS. The following paragraphs describe how to set each attribute's tolerance limit or limits. Refer to **Table 5-2** for a description of the range of values accepted for each command.

Programming The Power Supply Voltage Tolerance Limits

The power supply voltages are monitored to ensure that they are between an upper and a lower limit. The lower voltage tolerance limit is always the most negative, and the upper voltage tolerance limit is always the most positive. The following commands may be used to set the power supply voltage tolerance limits:

```
SENSE:VOLT1:RANGE:UPPER 5.2      -- +5V upper limit
SENSE:VOLT1:RANGE:LOWER 4.8      -- +5V lower limit
SENSE:VOLT2:RANGE:UPPER -5.0     -- -5.2V upper limit
SENSE:VOLT2:RANGE:LOWER -5.4     -- -5.2V lower limit
SENSE:VOLT3:RANGE:UPPER -1.8     -- -2V upper limit
SENSE:VOLT3:RANGE:LOWER -2.2     -- -2V lower limit
SENSE:VOLT4:RANGE:UPPER 25.9     -- +24V upper limit
SENSE:VOLT4:RANGE:LOWER 23.1     -- +24V lower limit
SENSE:VOLT5:RANGE:UPPER -23.1    -- -24V upper limit
SENSE:VOLT5:RANGE:LOWER -25.9    -- -24V lower limit
SENSE:VOLT6:RANGE:UPPER 12.9     -- +12V upper limit
SENSE:VOLT6:RANGE:LOWER 11.1     -- +12V lower limit
SENSE:VOLT7:RANGE:UPPER -11.1    -- -12V upper limit
SENSE:VOLT7:RANGE:LOWER -12.9    -- -12V lower limit
```

Each of these commands has an associated query. For example, the query:

```
SENSE:VOLT5:RANGE:LOWER?
```

reads the lower voltage tolerance limit for the -24V Power Supply. Refer to **Table 5-2** for a description of a range of values accepted for this command.

Programming The Power Supply Current Tolerance Limits

The power supply currents are monitored to ensure that they are below an upper limit. The following commands may be used to set the power supply current tolerance limits (examples show default limits programmed):

```
SENSE:CURR1:RANGE:UPPER 85.6    -- +5V upper limit
SENSE:CURR2:RANGE:UPPER 64.2    -- -5.2V upper limit
SENSE:CURR3:RANGE:UPPER 32.1    -- -2V upper limit
SENSE:CURR4:RANGE:UPPER 12.9    -- +24V upper limit
SENSE:CURR5:RANGE:UPPER 12.9    -- -24V upper limit
SENSE:CURR6:RANGE:UPPER 17.0    -- +12V upper limit
SENSE:CURR7:RANGE:UPPER 17.0    -- -12V upper limit
```

Each of these commands has an associated query. For example, the query:

```
SENSE:VOLT2:RANGE:UPPER?
```

reads the upper current tolerance limit for the -5.2V Power Supply. Refer to **Table 5-2** for a description of a range of values accepted for this command.

Programming The Fan Speed Tolerance Limits

The fan speeds are monitored to ensure that they are between the upper and lower limits. The following commands may be used to set the fan speed tolerance limits.

```
SENSE:FREQ1:RANGE:UPPER 6500    -- all 3 fans, upper limit
SENSE:FREQ1:RANGE:LOWER 2000    -- all 3 fans, lower limit
SENSE:FREQ2:RANGE:UPPER 7220    -- fan #1, upper limit
SENSE:FREQ2:RANGE:LOWER 3120    -- fan #1, lower limit
SENSE:FREQ3:RANGE:UPPER 6970    -- fan #2, upper limit
SENSE:FREQ3:RANGE:LOWER 2870    -- fan #2, lower limit
SENSE:FREQ4:RANGE:UPPER 7220    -- fan #3, upper limit
SENSE:FREQ4:RANGE:LOWER 2650    -- fan #3, lower limit
```

Each of these commands has an associated query. For example, the query:

```
SENSE:FREQ4:RANGE:LOWER?
```

reads the lower fan speed tolerance limit for fan #3. Refer to **Table 5-2** for a description of a range of values accepted for this command.

Programming The Ambient Temperature Tolerance Limits

The ambient temperature is monitored to ensure that it does not exceed an upper limit. The following command may be used to set the ambient temperature limit.

```
SENSE:TEMP14:RANGE:UPPER 63.0
```

This example sets the upper limit of the ambient temperature to 63 degrees Celsius. The present upper limit for the ambient temperature may be read with the query:

```
SENSE:TEMP14:RANGE:UPPER?
```

Refer to **Table 5-2** for a description of a range of values accepted for this command.

Programming The VXI Slot Temperature Tolerance Limits

Each VXI slot is individually monitored to ensure that the **temperature** does not exceed its programmable limit.

SENSE:TEMPerature<N> Commands

These commands set either the absolute temperature limits or relative temperature limits for the VXI chassis. The <N> following the TEMPerature indicates which temperature is being monitored.

TEMP1:RANG:UPP <temperature>	Temperature of VXI slot 0, relative
TEMP2:RANG:UPP <temperature>	Temperature of VXI slot 1, relative
TEMP3:RANG:UPP <temperature>	Temperature of VXI slot 2, relative
TEMP4:RANG:UPP <temperature>	Temperature of VXI slot 3, relative
TEMP5:RANG:UPP <temperature>	Temperature of VXI slot 4, relative
TEMP6:RANG:UPP <temperature>	Temperature of VXI slot 5, relative
TEMP7:RANG:UPP <temperature>	Temperature of VXI slot 6, relative
TEMP8:RANG:UPP <temperature>	Temperature of VXI slot 7, relative
TEMP9:RANG:UPP <temperature>	Temperature of VXI slot 8, relative
TEMP10:RANG:UPP <temperature>	Temperature of VXI slot 9, relative
TEMP11:RANG:UPP <temperature>	Temperature of VXI slot 10, relative
TEMP12:RANG:UPP <temperature>	Temperature of VXI slot 11, relative
TEMP13:RANG:UPP <temperature>	Temperature of VXI slot 12, relative
TEMP14:RANG:UPP <temperature>	Ambient Temperature
TEMP15:RANG:UPP <temperature>	Temperature of VXI slot 0, absolute
TEMP16:RANG:UPP <temperature>	Temperature of VXI slot 1, absolute
TEMP17:RANG:UPP <temperature>	Temperature of VXI slot 2, absolute
TEMP18:RANG:UPP <temperature>	Temperature of VXI slot 3, absolute
TEMP19:RANG:UPP <temperature>	Temperature of VXI slot 4, absolute
TEMP20:RANG:UPP <temperature>	Temperature of VXI slot 5, absolute
TEMP21:RANG:UPP <temperature>	Temperature of VXI slot 6, absolute
TEMP22:RANG:UPP <temperature>	Temperature of VXI slot 7, absolute
TEMP23:RANG:UPP <temperature>	Temperature of VXI slot 8, absolute
TEMP24:RANG:UPP <temperature>	Temperature of VXI slot 9, absolute
TEMP25:RANG:UPP <temperature>	Temperature of VXI slot 10, absolute
TEMP26:RANG:UPP <temperature>	Temperature of VXI slot 11, absolute
TEMP27:RANG:UPP <temperature>	Temperature of VXI slot 12, absolute

<temperature> range:

0.0 to 140.0 for relative temperature (default at 30.0 degrees C)

0.0 to 75.0 for absolute temperature (default at 55.0 degrees C)

Example: "SENS:TEMP22:RANG:UPP 58" set the alarm temperature for slot 7 to 58 degrees C.

These commands queries either the absolute temperature limits or relative temperature limits of the monitored VXI slot. The <N> following the TEMPerature indicates which temperature slot is being queried.

TEMP1:RANG:UPP?	Temperature of VXI slot 0, relative
TEMP2:RANG:UPP?	Temperature of VXI slot 1, relative
TEMP3:RANG:UPP?	Temperature of VXI slot 2, relative
TEMP4:RANG:UPP?	Temperature of VXI slot 3, relative
TEMP5:RANG:UPP?	Temperature of VXI slot 4, relative
TEMP6:RANG:UPP?	Temperature of VXI slot 5, relative
TEMP7:RANG:UPP?	Temperature of VXI slot 6, relative
TEMP8:RANG:UPP?	Temperature of VXI slot 7, relative
TEMP9:RANG:UPP?	Temperature of VXI slot 8, relative
TEMP10:RANG:UPP?	Temperature of VXI slot 9, relative
TEMP11:RANG:UPP?	Temperature of VXI slot 10, relative
TEMP12:RANG:UPP?	Temperature of VXI slot 11, relative
TEMP13:RANG:UPP?	Temperature of VXI slot 12, relative
TEMP14:RANG:UPP?	Ambient Temperature
TEMP15:RANG:UPP?	Temperature of VXI slot 0, absolute
TEMP16:RANG:UPP?	Temperature of VXI slot 1, absolute
TEMP17:RANG:UPP?	Temperature of VXI slot 2, absolute
TEMP18:RANG:UPP?	Temperature of VXI slot 3, absolute
TEMP19:RANG:UPP?	Temperature of VXI slot 4, absolute
TEMP20:RANG:UPP?	Temperature of VXI slot 5, absolute
TEMP21:RANG:UPP?	Temperature of VXI slot 6, absolute
TEMP22:RANG:UPP?	Temperature of VXI slot 7, absolute
TEMP23:RANG:UPP?	Temperature of VXI slot 8, absolute
TEMP24:RANG:UPP?	Temperature of VXI slot 9, absolute
TEMP25:RANG:UPP?	Temperature of VXI slot 10, absolute
TEMP26:RANG:UPP?	Temperature of VXI slot 11, absolute
TEMP27:RANG:UPP?	Temperature of VXI slot 12, absolute

These commands set the monitoring mode to either absolute or relative and query the current monitoring mode of the EMS.

TEMP:MODE 0 Set the monitoring mode to absolute (new mode)

TEMP:MODE 1 Set the monitoring mode to relative (old mode)

The default monitoring mode is absolute (0 – new mode)

TEMP:MODE? Returns the current monitoring mode

The reply to the query is 0 or 1 for new mode or old mode respectively.

Programming The VXI Bus Error and IACKn Tolerance Limits

The EMS provides monitoring of the VXI Bus Error or IACKn events. Only one of the following events may be monitored at one time:

Bus Error (BERR*)
IACK1, IACK2, IACK3, ..., IACK7

Programming an upper limit for any of these events results in all other events being ignored by the EMS. The following commands may be used to set the upper limit for either the Bus Error or IACK events:

```
SENSE:VXI:BERR:LIMIT 255 -- set BERR limit
SENSE:VXI:IACK1:LIMIT 128 -- set IACK1 limit
SENSE:VXI:IACK2:LIMIT 233 -- set IACK2 limit
SENSE:VXI:IACK3:LIMIT 1 -- set IACK3 limit
SENSE:VXI:IACK4:LIMIT 2 -- set IACK4 limit
SENSE:VXI:IACK5:LIMIT 3 -- set IACK5 limit
SENSE:VXI:IACK6:LIMIT 44 -- set IACK6 limit
SENSE:VXI:IACK7:LIMIT 113 -- set IACK7 limit
```

Each limit may be set to an integer value between 0 and 255. Setting the limit to 0 disables the monitoring of the BERR and all IACK lines.

Each of the commands has an associated query which may be used to read the present limit for the BERR or IACK line. For example, the query:

```
SENSE:VXI:IACK5:LIMIT?
```

reads the presently programmed limit for the IACK5 line. Refer to **Table 5-2** for a description of a range of values accepted for this command.

Reading The VXI Bus Error and IACKn Counters

The present count of Bus Error (BERR) or Interrupt Acknowledge cycles (IACKn) may be read back from the EMS. Only the presently monitored event will return a non-zero count value; all others will return a count of 0. For example, if the "SENSE:VXI:IACK3:LIMIT 7" command is received, then the BERR, IACK1, IACK2, and IACK4 through IACK7 count values will be returned as zero.

The following queries may be used to read the present count of VXI Bus Error and Interrupt Acknowledge events.

```
SENSE:VXI:BERR:COUNT? -- read BERR count
SENSE:VXI:IACK1:COUNT? -- read IACK1 count
```

```

SENSE:VXI:IACK2:COUNT? -- read IACK2 count
SENSE:VXI:IACK3:COUNT? -- read IACK3 count
SENSE:VXI:IACK4:COUNT? -- read IACK4 count
SENSE:VXI:IACK5:COUNT? -- read IACK5 count
SENSE:VXI:IACK6:COUNT? -- read IACK6 count
SENSE:VXI:IACK7:COUNT? -- read IACK7 count

```

Clearing The VXI Bus Error and IACKn Counters

The present count of Bus Error (BERR) or Interrupt Acknowledge cycles (IACKn) may be cleared to zero. This is necessary since the count increases to a maximum value of 256. Once the count reaches 256, the only way to clear it is to use the command described below (or to select some other IACKn or BERR line for monitoring).

The following commands may be used to clear the BERR or IACKn counters:

```

SENSE:VXI:BERR:CLEAR -- clear BERR counter
SENSE:VXI:IACK1:CLEAR -- clear IACK1 counter
SENSE:VXI:IACK2:CLEAR -- clear IACK2 counter
SENSE:VXI:IACK3:CLEAR -- clear IACK3 counter
SENSE:VXI:IACK4:CLEAR -- clear IACK4 counter
SENSE:VXI:IACK5:CLEAR -- clear IACK5 counter
SENSE:VXI:IACK6:CLEAR -- clear IACK6 counter
SENSE:VXI:IACK7:CLEAR -- clear IACK7 counter

```

This command is meaningful only if the specified event is presently being monitored. If, for example, the IACK3 line is presently being monitored (because a "SENSE:VXI:IACK3:LIMIT" command was executed), then clearing the counter for the BERR event will have no effect.

Generating an Interrupt When an Alarm Condition is Detected

The previous paragraphs have described how to program tolerance limits. When one of the attributes monitored by the EMS exceeds its tolerance limits, an alarm condition exists. The following paragraphs describe how to program the EMS to generate an interrupt when it detects an alarm condition.

The EMS uses the SCPI-defined mechanism for generating interrupts based on out-of-tolerance conditions. The EMS implements a 3-level hierarchy of status registers to provide for enabling and disabling of interrupts based upon the individual VXI attributes monitored.

At the highest level, a separate condition, event, and enable register is maintained for each of the following attributes:

Power Supply Voltages
 Power Supply Currents
 Fan Speed
 VXI Slot Temperatures
 Elapsed Time
 VXI Bus Error and IACK Events

Thus, there is a “Voltage Condition Register”, a “Voltage Event Register”, a “Voltage Enable Register”, a “Current Condition Register”, a “Current Event Register”, and so on.

The “Condition Register” holds the present status of each of the individual items monitored. For example, the “Voltage Condition Register” has a total of seven meaningful bits (see **Figure 4-1**). Each bit represents the present in-tolerance/out-of-tolerance state of a single power supply voltage.

Bit 0 (the least significant bit) is set to 1 if the voltage for the +5V power supply voltage is out of the programmable tolerance limits. This bit is cleared to 0 if the +5V power supply voltage is within the tolerance limits.

Similarly, bit 1 is set if the -5.2V power supply voltage is out of tolerance, and cleared to 0 if it is in tolerance. The other bit assignments for the “Voltage Condition Register” are shown in **Figure 4-1**.

Bits 15 through 7 Not assigned/ Always 0	Bit 6 -12V PS	Bit 5 +12V PS	Bit 4 -24V PS	Bit 3 +24V PS	Bit 2 -2V PS	Bit 1 -5.2V PS	Bit 0 +5V PS
--	---------------------	---------------------	---------------------	---------------------	--------------------	----------------------	--------------------

Figure 4-1, Voltage Condition Register

The Voltage Condition Register may be read with the query:

```
STAT:QUES:VOLT:COND?
```

This query returns an integer value in the range 0 to 127. The value is formed by adding the bit values of each of the status bits. For example, the value of 97 (64 + 32 + 1) indicates that the -12V (64), +12V (32), and +5V (1) power supplies are out of tolerance.

Each attribute monitored by the 1261B EMS has its own “Condition Register”. The remaining condition registers may be read with the following queries:

```
STAT:QUES:CURR:COND?    -- Current Condition
STAT:QUES:TEMP:COND?    -- Temperature Condition
STAT:QUES:FREQ:COND?    -- Fan Condition
```

STAT:QUES:TIME:COND? -- Elapsed Time Condition
 STAT:QUES:VXI:COND? -- VXI BERR/IACK Condition

The bit assignments for the various Condition Registers are shown in **Tables 4-1** through **Tables 4-6**.

Table 4-2, Voltage Condition and Event Register Bit Assignments

Bit	Set When
0	+5V Power Supply Voltage out of tolerance
1	-5.2V Power Supply Voltage out of tolerance
2	-2V Power Supply Voltage out of tolerance
3	+24V Power Supply Voltage out of tolerance
4	-24V Power Supply Voltage out of tolerance
5	+12V Power Supply Voltage out of tolerance
6	-12V Power Supply Voltage out of tolerance

Table 4-3, Current Condition and Event Register Bit Assignments

Bit	Set When
0	+5V Power Supply Current out of tolerance
1	-5.2V Power Supply Current out of tolerance
2	-2V Power Supply Current out of tolerance
3	+24V Power Supply Current out of tolerance
4	-24V Power Supply Current out of tolerance
5	+12V Power Supply Current out of tolerance
6	-12V Power Supply Current out of tolerance

Table 4-4, Temperature Condition and Event Register Bit Assignments

Bit	Set When
0	VXI slot 0 temperature rise exceeds limit
1	VXI slot 1 temperature rise exceeds limit
2	VXI slot 2 temperature rise exceeds limit
3	VXI slot 3 temperature rise exceeds limit
4	VXI slot 4 temperature rise exceeds limit
5	VXI slot 5 temperature rise exceeds limit
6	VXI slot 6 temperature rise exceeds limit
7	VXI slot 7 temperature rise exceeds limit
8	VXI slot 8 temperature rise exceeds limit
9	VXI slot 9 temperature rise exceeds limit
10	VXI slot 10 temperature rise exceeds limit
11	VXI slot 11 temperature rise exceeds limit
12	VXI slot 12 temperature rise exceeds limit
13	Ambient temperature exceeds limit

Table 4-5, Fan Speed Condition and Event Register Bit Assignments

Bit	Set When
0	Fan #1, #2, or #3 is out of tolerance
1	Fan #1 is out of tolerance
2	Fan #2 is out of tolerance
3	Fan #3 is out of tolerance

Table 4-6, Time Condition and Event Register Bit Assignments

Bit	Set When
0	Present Power-On Time exceeds limit
1	Cumulative Power-On Time exceeds limit
2	Filter Service Time exceeds limit

Table 4-7, VXI Condition and Event Register Bit Assignments

Bit	Set When
0	VXI Bus Error (BERR*) Count exceeds limit
1	VXI SYSFAIL* is asserted
2	VXI ACFAIL* is asserted
3	VXI IACK1 Count exceeds limit
4	VXI IACK2 Count exceeds limit
5	VXI IACK3 Count exceeds limit
6	VXI IACK4 Count exceeds limit
7	VXI IACK5 Count exceeds limit
8	VXI IACK6 Count exceeds limit
9	VXI IACK7 Count exceeds limit

The “Event Register” holds the latched status of each of the individual items monitored. Each “Event Register” has the same bit assignment as the corresponding “Condition Register”. Thus, the “Voltage Event Register” has the same bit assignment as that shown in **Figure 4-1**.

The difference between the “Condition Register” and the “Event Register” is that the “Event Register” holds **latched** status

information, while the “Condition Register” holds the **present** status information. For example, if the -12V power supply voltage goes out of tolerance and then returns in tolerance, bit 6 of the “Voltage Condition Register” will be 0 while bit 6 of the “Voltage Event Register” will be 1.

The following queries may be used to read the various attributes’ Event Registers:

```
STAT:QUES:VOLT:EVENT?  -- Voltage Event Register
STAT:QUES:CURR:EVENT?  -- Current Event Register
STAT:QUES:TEMP:EVENT?  -- Temperature Event Reg.
STAT:QUES:FREQ:EVENT?  -- Fan Speed Event Reg.
STAT:QUES:TIME:EVENT?  -- Elapsed Time Event Reg.
STAT:QUES:VXI:EVENT?   -- VXI Event Register
```

Each time the “Event Register” is read, the bits of the “Event Register” are cleared. The bits of the “Event Register” are only set on a transition from an in-tolerance state to out-of-tolerance state. This corresponds to a 0-to-1 transition of the “Condition Register”.

The “Enable Register” determines which of the “Event Register” bits will be passed onto the next level of status reporting. The value of the “Event Register” and “Enable Register” are logically ANDed together. If any of the bits of both registers are set, the status summary bit passed onto the next level of status reporting is also set. This is shown in **Figure 4-2**.

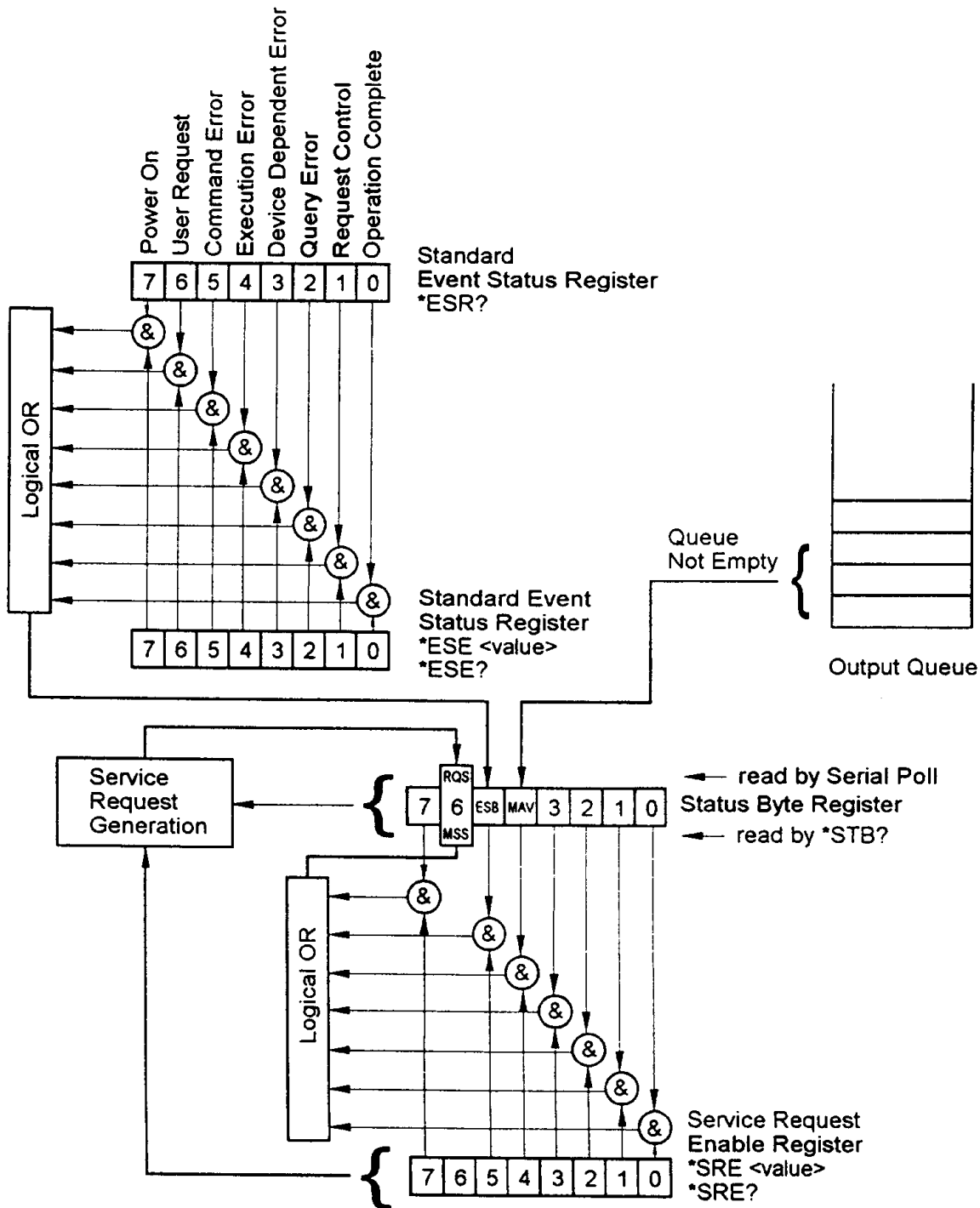

Figure 4-2, Event and Enable Registers and Summary Bit Generation

The Enable Registers for each attribute may be set with the following commands (arbitrary register values are shown)

```

STAT:QUES:VOLT:ENAB 127 -- Voltage Enable
STAT:QUES:CURR:ENAB 31 -- Current Enable
STAT:QUES:TEMP:ENAB 7 -- Temperature Enable
STAT:QUES:TIME:ENAB 15 -- Elapsed Time Enable
STAT:QUES:FREQ:ENAB 15 -- Fan Speed Enable
STAT:QUES:VXI:ENAB 255 -- VXI Enable

```

Each of the monitored attributes have an Event Register and an Enable Register. For each attribute, the registers are logically ANDed together, and the result is Ored to form a status summary bit. Each attribute is represented in the "Questionable Condition" register by a single summary bit. The bit assignments for the "Questionable Condition" register is shown in **Table 4-8**.

Table 4-8, Questionable Condition Register Bit Assignment

Bit	Set When
0	Voltage Event AND Enable bit or bits set
1	Current Event AND Enable bit or bits set
2	Time Event AND Enable bit or bits set
3	Not Assigned/always 0
4	Temperature Event AND Enable bit or bits set
5	Fan Speed Event AND Enable bit or bits set
6	Not Assigned/always 0
7	Not Assigned, always 0
8	Not Assigned, always 0
9	VXI Event AND Enable bit or bits set
10	Not Assigned, always 0
11	Not Assigned, always 0
12	Not Assigned, always 0
13	Not Assigned, always 0
14	Not Assigned, always 0
15	Not Assigned, always 0

The Questionable Condition Register may be read with the query

```
STATUS:QUES:COND?
```

This query returns an integer value in the range 0 to 575.

In addition to the Questionable Condition Register, the 1261B EMS implements a "Questionable Event Register" and a "Questionable Enable Register". These act identically to the "Event Registers" and "Enable Registers" associated with each of the attributes.

The "Questionable Event Register" contains the latched status of all of the attribute summary bits. This means that a bit in the "Questionable Event Register" is set when the corresponding bit of the "Questionable Condition Register" transitions from a 0 to a 1.

The Questionable Event Register may be read with the query:

```
STATUS:QUES:EVENT?
```

The "Questionable Enable Register" enables bits in the "Questionable Event Register" to set bit 3 of the IEEE-488.2 defined Status Byte. Bit 3 of the Status Byte is the status summary for all enabled "Questionable Event Register" bits.

The Questionable Enable Register may be set with the command:

```
STATUS:QUES:ENABLE 32767
```

This example enables all of the bits of the Questionable Event Register to set bit 3 of the Status Byte.

The status reporting hierarchy is shown in **Figure 4-3**.

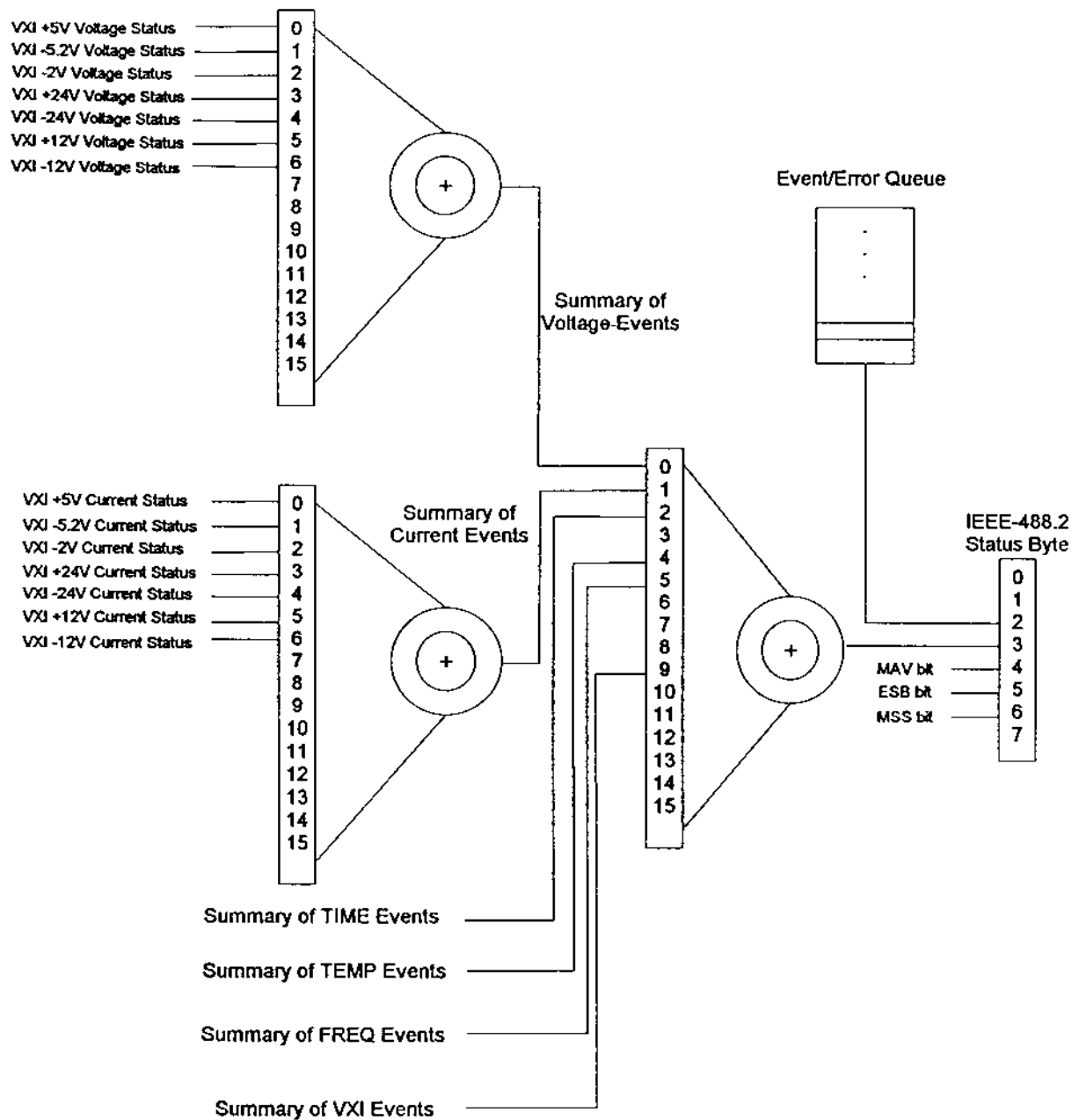

Figure 4-3, Status Reporting Hierarchy

The final step for enabling out-of-tolerance conditions to generate an interrupt is to enable bit 3 of the Status Byte to generate an interrupt. The IEEE-488.2 “*SRE” command is used to enable bits of the Status Byte to generate an interrupt. Thus, if bit 3 of the “SRE Register” value is set, then an interrupt will be generated by the EMS when bit 3 of the Status Byte becomes set.

The following example enables bit 3 and bit 0 of the Status Byte. When either of the bits transition from a 0 to a 1, an interrupt will be generated:

```
*SRE 9
```

Clearing The Filter Service Alarm

The EMS maintains a “power-on” clock. This clock counts each second that the mainframe power switch is turned to the ON state. This clock is used to determine both the cumulative power-on time and the power-on time which has elapsed since the last time the filter was cleaned.

The time interval for cleaning the filter is set using the “SENSE:TIME3:RANGE:UPPER” command. This command sets the number of seconds which must elapse the mainframe power ON before the Filter Service Alarm is generated.

The number of seconds which has elapsed (with the mainframe power on) since the last filter service may be read using the “MEAS:TIME3?” command. This command calculates the difference between the present value of the “power-on” clock and a reference time stored in an EEPROM on the EMS.

After the “SENSE:TIME3:RANGE:UPPER” time has elapsed, the Filter Service Alarm is generated. This alarm will set bit 2 of the Questionable Time Condition and Event Registers (see **Table 4-5**). These registers may be read using the “STATUS:QUES:TIME:COND?” and “STATUS:QUES:TIME:EVENT?” queries, respectively. Bit 2 of the Questionable Time Event register will be cleared the first time “STATUS:QUES:TIME:EVENT?” query is executed. Bit 2 of the Questionable Time Condition register will remain set as long as the Filter Service Alarm is active.

The Filter Service Alarm may be cleared by executing the “SENSE:TIME3:CLEAR” command. This command stores the present value of the “power-on” clock as the reference time used to calculate the elapsed filter service time. Thus, if the “SENSE:TIME3:CLEAR” command is followed immediately by a

“MEAS:TIME3?” command, the “MEAS:TIME3?” command will return a value of **0**.

Therefore, the “SENSE:TIME3:CLEAR” command should be executed immediately after the filter is cleaned and mainframe power is turned on.

Change of Limit for Filter Service Alarm Example

To display a failure message after 100 days (example) of “power-on time” the following sequence may be performed:

- A. Locate DIP switch SW1-8 on the EMS board. Move the switch to ON position. This allows the EMS to read the limits at power-up from the on-board EEPROM. The limits are read from the nonvolatile location 0. This location is stored using the command “SAV 0”.
- B. Using the following SCPI commands:
 1. SENSE: TIME3: CLEAR
 2. SENSE: TIME3: RANGE: UPPER 15.768E6.
15.768E6 is an example representing 15768000 or 182 days.
 3. *SAV 0

You have just set the Filter Service Alarm to be active in 182 days of power-on.

Interrupt Generation Example

As an example, suppose an interrupt is desired only when one or more of the following conditions exist:

- 1) +24V Power Supply Voltage is out of tolerance
- 2) -12V Power Supply Voltage is out of tolerance
- 3) +12V Power Supply Current is out of tolerance
- 4) -12V Power Supply Current is out of tolerance
- 5) VXI Slot 7 Temperature Rise is too high
- 6) Fan #2 speed is out of tolerance

No other condition should generate an interrupt.

To provide for this combination, execute the following commands:

- Enable +24V and -12V Power Supply Voltage only
STAT:QUES:VOLT:ENABLE 72
- Enable +12V and -12V Power Supply Current
STAT:QUES:CURR:ENABLE 96
- Enable VXI Slot 7 Temperature Rise

```
STAT:QUES:TEMP:ENABLE 128
-- Enable Fan #2 Speed
STAT:QUES:FREQ:ENABLE 4
-- Enable all bits of the Questionable Enable Register
STAT:QUES:ENABLE 32767
-- Enable bit 3 of the IEEE-488.2 Status Byte
*SRE 8
```

When an interrupt is detected by the system controller, it must check to see which condition generated the condition. To do this, it must:

- 1) Read the Questionable Event Register to see which attribute caused the interrupt. Recall that this register is read with the "STAT:QUES:EVENT?" query.
- 2) If the Voltage Summary bit (bit 0) is set, then read the Questionable Voltage Event Register to determine which supply is out of tolerance. The Questionable Voltage Event Register may be read with the

"STAT:QUES:VOLT:EVENT?" query.
- 3) If the Current Summary bit (bit 1) is set, read the Questionable Current Event Register to determine which supply is out of tolerance. The Questionable Current Event Register may be read with the "STAT:QUES:CURR:EVENT?" register.
- 4) If the Temperature Summary bit (bit 4) is set, it must be caused by VXI slot 7 temperature rise, since that is the only slot enabled in this example.
- 5) If the Frequency Summary bit (bit 5) is set, it must be caused by fan #2 since that is the only fan enabled in this example.

The example enables only a few attributes to generate an interrupt. For most users, all out-of-tolerance conditions should be investigated. Therefore, for most users, all of the Enable Registers should be set to a value of 32767 so all monitored attributes are capable of generating an interrupt.

Programming The Trigger Subsystem

The 1261B provides the following trigger capabilities:

- 1) Route a signal from the TRIG IN front panel input connector to one of the TTLTRG lines on the VXI backplane;
- 2) Route a signal from one of the TTLTRG lines on the VXI backplane to the TRIG OUT front panel output connector;
- 3) Apply a programmable delay between either the TRIG IN signal and the TTLTRGx line or the TTLTRGx signal and the TRIG OUT line.
- 4) Route the TRIG IN front panel input signal directly to the TRIG OUT front panel output (with or without a delay).

Note that by routing the TRIG IN input to the same TTLTRGx line that is connected to the TRIG OUT output, the TRIG IN signal may be connected to the TRIG OUT connector in addition to the TTLTRGx line.

Connecting The TRIG IN Input To a TTLTRG Line

The TRIG IN input may be connected to one of the TTLTRGx lines (TTLTRG0 through TTLTRG7) . The following commands may be used to connect the TRIG IN input to one of the TTLTRG lines, or to disconnect the input from all of the TTLTRG lines:

```
VXI:CONF:MONITOR:TRIG:INPUT TTLTRG0
VXI:CONF:MONITOR:TRIG:INPUT TTLTRG1
VXI:CONF:MONITOR:TRIG:INPUT TTLTRG2
VXI:CONF:MONITOR:TRIG:INPUT TTLTRG3
VXI:CONF:MONITOR:TRIG:INPUT TTLTRG4
VXI:CONF:MONITOR:TRIG:INPUT TTLTRG5
VXI:CONF:MONITOR:TRIG:INPUT TTLTRG6
VXI:CONF:MONITOR:TRIG:INPUT TTLTRG7
VXI:CONF:MONITOR:TRIG:INPUT NONE
```

The first eight commands above connect the TRIG IN input to TTLTRG0 through TTLTRG7 respectively. The last command disconnects the TRIG IN input from all of the TTLTRG lines.

Note that by selecting one TTLTRG line, all other TTLTRG lines are implicitly disconnected.

To determine which line is presently connected, the query:

```
VXI:CONF:MONITOR:TRIG:INPUT?
```

may be used.

The reply to this query will be one of the following:

```
TTLT0
TTLT1
TTLT2
TTLT3
TTLT4
TTLT5
TTLT6
TTLT7
NONE
```

The Default state for this command is "NONE".

Connecting The TRIG OUT Output To a TTLTRG Line

The TRIG OUT output may be connected to one of the TTLTRGx lines (TTLTRG0 through TTLTRG7) . The following commands may be used to connect the TRIG OUT output to one of the TTLTRG lines, or to disconnect the input from all of the TTLTRG lines:

```
VXI:CONF:MONITOR:TRIG:OUTPUT TTLTRG0
VXI:CONF:MONITOR:TRIG:OUTPUT TTLTRG1
VXI:CONF:MONITOR:TRIG:OUTPUT TTLTRG2
VXI:CONF:MONITOR:TRIG:OUTPUT TTLTRG3
VXI:CONF:MONITOR:TRIG:OUTPUT TTLTRG4
VXI:CONF:MONITOR:TRIG:OUTPUT TTLTRG5
VXI:CONF:MONITOR:TRIG:OUTPUT TTLTRG6
VXI:CONF:MONITOR:TRIG:OUTPUT TTLTRG7
VXI:CONF:MONITOR:TRIG:OUTPUT NONE
VXI:CONF:MONITOR:TRIG:OUTPUT INPUT
VXI:CONF:MONITOR:TRIG:OUTPUT DFI
```

The first eight commands above connect the TRIG OUT output to TTLTRG0 through TTLTRG7, respectively. The ninth command disconnects the TRIG OUT output from all of the TTLTRG lines. The last command connects the TRIG IN input to the TRIG OUT output without affecting any of the TTLTRG lines. In this case, if the TRIG IN input is already connected to a TTLTRG line, it will be disconnected prior to connecting it to the TRIG OUT output.

Note that by selecting one TTLTRG line, all other TTLTRG lines are implicitly disconnected.

To determine which line is presently connected, the query:

```
VXI:CONF:MONITOR:TRIG:OUTPUT?
```

may be used. The reply to this query will be one of the following:

```
TTLT0  
TTLT1  
TTLT2  
TTLT3  
TTLT4  
TTLT5  
TTLT6  
TTLT7  
NONE  
INP  
DFI
```

The Default state for this command is “NONE”.

Discrete Fault Indicator

Discrete Fault Indicator (DFI) allows the user to either connect an external alarm, eg. A Sona-Alert, close an external relay to sound a larger alarm or turn on an emergency flashing light if the 1261B chassis EMS module senses an alarm condition.

When enabled the DFI would output a true on the “TRIG OUTPUT TTL” line (low), J413-2, when any of the following errors occur:

- 1) Over Current on any rail.
- 2) Over Voltage on any rail.
- 3) Under Voltage on any rail.
- 4) Over Ambient Temperature (55°C).
- 5) Over Slot Temperature maximum (55°C) of any slot.
- 6) Fans below minimum fan speed of 2000 RPM.

Programming the Discrete Fault Indicator

The default mode is DFI OFF after power up or RESET. To enable the DFI operation send:

```
VXI:CONF:MONITOR:TRIG:OUTPUT DFI
```

To confirm the DFI is on send:

```
VXI:CONF:MON:TRIG:OUTPUT?
```

Reply is “DFI”

Testing the DFI Operation

A piezo electric alarm can be connected in the following manner. Connect J413-2 to the minus terminal of the alarm. (TRIG OUT). Connect J414-1 to the plus terminal of the alarm (+5VDC).

Use the VIC program to send the command:

```
VXI:CONF:MONITOR:TRIG:OUTPUT DFI
```

Run 1261B EMS Soft Front Panel
Go the Voltage Set Limit screen
Set the +5VDC limit to "5.00"
The DFI TRIG OUT will Switch to low turning on the Alarm.

Change the +5VDC limit back to the default value of "5.25".

Programming a Trigger Delay Time

A delay time may be added between:

- 1) The TRIG IN input and the selected TTLTRGx line, OR
- 2) The TTLTRGx line and the TRIG OUT output, OR
- 3) The TRIG IN input and the TRIG OUT output

The trigger delay time ranges from 0.0 to 1.04857596875 seconds in steps of 31.25 nanoseconds. To program a delay time, the command:

```
VXI:CONF:MONITOR:TRIG:DELAY <delay time>
```

where "<delay time>" ranges between 0.0 and 1.04857596875.

NOTE

When the trigger delay is non-zero, the trigger pulse is generated from the 1261B EMS. It is not identical to the trigger signal applied to the input (or from the TTLTRGx line). The trigger pulse is approximately 100 nanoseconds wide and is a low-going (normally high) pulse.

NOTE

The EMS trigger delay circuit adds a delay between the input and output pulses. This delay is between 31.25 ns and 62.5 ns (typical, 100 ns maximum).

The present delay time may be read back with the query:

```
VXI:CONF:MONITOR:TRIG:DELAY?
```

The reply to this query is a numeric value formatted as a real number.

Selecting The Trigger Delay Application

The trigger delay may be placed between ONE of the following:

- 1) TRIG IN input to selected TTLTRG line
- 2) Selected TTLTRG line to TRIG OUT output
- 3) TRIG IN input to TRIG OUT output
- 4) Nothing (no delay)

The following commands may be used to select the delay application:

```
VXI:CONF:MONITOR:TRIG:DELAY:STATE INPUT
VXI:CONF:MONITOR:TRIG:DELAY:STATE OUTPUT
VXI:CONF:MONITOR:TRIG:DELAY:STATE NONE
```

The first command applies the delay between the TRIG IN input and the selected TTLTRG line. The second command places the delay between the selected TTLTRG line (or TRIG IN input) and the TRIG OUT output. The third command removes any trigger delay from the trigger subsystem.

The present trigger delay application may be read using the query:

```
VXI:CONF:MONITOR:TRIG:DELAY:STATE
```

The reply to this query will be one of the following:

```
INP
OUTP
NONE
```

Programming The Front Panel Display

The EMS has a 10 character LED display which is capable of displaying all printable characters. This includes both uppercase and lowercase "A" through "Z", the comma, single quote, double quote, forward and backward slash, asterisk, dollar sign, percent sign, and so on. A space character may also be displayed.

At Power-On and after a reset command (“*RST”), the front panel display is turned on. The front panel will display the message:

```
Standby
```

if the AC line power switch is off. If the AC line power switch is on, the front panel will display the message:

```
System OK
```

These two messages are displayed only when no out-of-tolerance conditions have been detected by the EMS. If an out-of-tolerance condition is detected, a status message is displayed. Consult the “Front Panel Display Status Messages” of this chapter for a description of the various status messages and their meanings.

Turning The Display On and Off

At Power-On and after a reset, the front panel display is turned on. The front panel may be turned off using the command:

```
DISPLAY:TEXT:STATE OFF
```

After this command is executed, the display is turned off. The display will not display any status messages nor will it display any user-defined messages.

The front panel display may be turned on by using the command:

```
DISPLAY:TEXT:STATE ON
```

The present state of the display may be read using the query:

```
DISPLAY:TEXT:STATE?
```

The EMS will reply to this query with a “0” if the display is off, or a “1” if the display is on.

Writing a Message To The Display

The user may write a message to the display. This is done with the command:

```
DISPLAY:TEXT "Show This On The Display"
```

This text to display may be enclosed in either double quotes or in single quotes.

The text message may be from 0 to 80 characters in length.

Since the LED display can accommodate only 10 characters at a time, and since the status "clock" is always shown at the right-most position, only 9 characters may be displayed at one time. The EMS will automatically "scroll" messages longer than 9 characters from left to right at the rate of 2 characters per second. Thus, if the command:

```
DISPLAY:TEXT "This is My String"
```

is executed, then the front panel will show the following characters in succession:

```
This is M  
his is My  
is is My  
s is My S  
is My St  
is My Str  
s My Stri  
My Strin  
My String
```

The presently programmed text string may be read using the query:

```
DISPLAY:TEXT?
```

The EMS will reply to this query with the string enclosed in double quotes. If a double quote is part of the displayed string, then two consecutive double quotes will be shown in the reply as follows:

```
"This has a double quote "" embedded in it"
```

The user string may be set to a length of 0 by sending the command:

```
DISPLAY:TEXT ""
```

If this command is executed, the display will show nothing UNLESS an out-of-tolerance condition is detected by the EMS.

Clearing The Message From The Display

The user message may be cleared entirely by executing the command:

```
DISPLAY:TEXT:CLEAR
```

After this command has been executed, the EMS will behave as if no user message has been defined. This will then return to displaying the "System OK" or out-of-tolerance message(s).

Front Panel Message Semantics

The EMS updates the front panel display as illustrated by the following pseudocode:

```
If the display state is ON then
  If there is an out-of-tolerance condition then
    display out-of-tolerance message
  Elsif there is a user-defined message then
    display the user-defined message
  Elsif the AC line power is switch ON then
    display "System OK"
  Else
    display "Standby"
  Endif
Endif
```

Front Panel Status Messages

In the event that the EMS detects an out-of-tolerance condition, the front panel display will be updated with a status message. The status messages and their meanings are shown in **Table 4-8**.

Table 4-9, Front Panel Status Messages

Message	Meaning
System OK	AC Power switch is ON, nothing out-of-tolerance
Standby	AC power switch is OFF, nothing out-of-tol
+5V PS OV	+5V power supply over-voltage condition
-5V PS OV	-5.2V power supply over-voltage condition
-2V PS OV	-2V power supply over-voltage condition
+24V PS OV	+24V power supply over-voltage condition
-24V PS OV	-24V power supply over-voltage condition
+12V PS OV	+12V power supply over-voltage condition
-12V PS OV	-12V power supply over-voltage condition
+5V PS UV	+5V power supply under-voltage condition
-5V PS UV	-5.2V power supply under-voltage condition
-2V PS UV	-2V power supply under-voltage condition
+24V PS UV	+24V power supply under-voltage condition
-24V PS UV	-24V power supply under-voltage condition
+12V PS UV	+12V power supply under-voltage condition
-12V PS UV	-12V power supply under-voltage condition
+5V PS OC	+5V power supply over-current condition
-5V PS OC	-5.2V power supply over-current condition
-2V PS OC	-2V power supply over-current condition
+24V PS OC	+24V power supply over-current condition
-24V PS OC	-24V power supply over-current condition
+12V PS OC	+12V power supply over-current condition
-12V PS OC	-12V power supply over-current condition
FAN X SPEED	Fan X speed is out of tolerance (X will be "1", "2", or "3")
AMB TEMP H	Ambient Temperature is too high
SLOT XX T	Slot XX temperature rise is too high (XX will be "1" to "12")

Table 4-9, Front Panel Status Messages (continued)

Message	Meaning
IACKX CNT	Interrupt Acknowledge Line X count reached (X will be "1" to "7")
BERR CNT	Bus Error count reached
SYSFAIL	SYSFAIL* line asserted
ACFAIL	ACFAIL* line asserted
PON TIME	Elapsed power-on time limit reached
TOT PON TM	Elapsed cumulative power-on time limit reached
FILTER	Filter service time limit reached

Each of these messages will be flashed on the display. If more than one out-of-tolerance condition is detected, each status message will be displayed in a round-robin fashion.

Programming The RS-232 Interface

The EMS includes an RS-232 interface which may be used to send commands and receive replies. The RS-232 interface operates at one of four baud rates: 1200, 2400, 4800, or 9600. It supports 7 or 8 data bits, even, odd, or no parity, and 1 or 2 stop bits.

The default baud rate, data bits, stop bits, and parity are selected using DIP switch SW1. These settings will be used upon power on or upon reset. Consult the configuration diagram in section 2 of this manual for switch settings of SW1.

The baud rate, data bits, stop bits, and parity may be programmed using commands over the VXIbus or over the RS-232 interface.

Programming The Baud Rate

The baud rate may be programmed using the command:

```
SYSTEM:COMM:SERIAL:BAUD <baud rate>
```

where "<baud rate>" will be one of the following: 1200, 2400, 4800 or 9600. The present baud rate may be read back using the query

```
SYSTEM:COMM:SERIAL:BAUD?
```

The EMS will reply with one of the four possible values.

Programming The Number of Data Bits

The number of data bits may be programmed with the command:

```
SYSTEM:COMM:SERIAL:BITS <data bits>
```

where “<data bits>” will either be 7 or 8. The presently programmed number of data bits may be read with the query:

```
SYSTEM:COMM:SERIAL:BITS?
```

Programming The Parity

The parity may be programmed using one of the following commands:

```
SYSTEM:COMM:SERIAL:PARITY EVEN  
SYSTEM:COMM:SERIAL:PARITY ODD  
SYSTEM:COMM:SERIAL:PARITY NONE
```

The present parity may be read using the query:

```
SYSTEM:COMM:SERIAL:PARITY?
```

The EMS will reply to this query with one of the following:

```
EVEN  
ODD  
NONE
```

Programming The Number of Stop Bits

The number of data bits may be programmed with the command:

```
SYSTEM:COMM:SERIAL:SBITS <stop bits>
```

where “<stop bits>” will either be 1 or 2. The presently programmed number of stop bits may be read with the query:

```
SYSTEM:COMM:SERIAL:SBITS?
```

Illegal RS-232 Interface Combinations

The following combinations of parity, data bits, and stop bits are NOT supported

- No parity, 7 data bits, 1 stop bit
- Even parity, 8 data bits, 2 stop bits
- Odd parity, 8 data bits, 2 stop bits

If an attempt is made to program one of these combinations, the command will be ignored, and an error will be generated and placed in the instrument's "error queue". The error generated will be error number -221 ("Settings conflict"). Consult the SCPI reference section of this manual for a complete description of error messages.

As an example, suppose that the system presently has the following RS-232 configuration:

- 9600 baud
- 1 stop bit
- no parity
- 8 data bits

Suppose also that the following configuration is desired:

- 9600 baud
- 1 stop bit
- even parity
- 7 data bits

Then the parity must be programmed BEFORE the number of data bits is programmed. If an attempt is made to program the number of data bits to 7 before the parity is set to even, then an illegal combination would (temporarily) result. That is, the combination would be:

- 9600 baud, 1 stop bit, no parity, 7 data bits

which is NOT allowed. Thus, the commands must be sent in the following order:

```
SYSTEM:COMM:SERIAL:PARITY  EVEN
SYSTEM:COMM:SERIAL:BITS      7
```

Note that the order of programming will have to change based upon what the present configuration is and what the desired configuration is. That is, if we go from:

- 9600 baud, 1 stop bit, even parity, 7 data bits

to:

9600 baud, 1 stop bit, no parity, 8 data bits

then the number of data bits must be programmed first.

To read the Baud Rate.

```
SYSTEM:COMM:SER:TRAN:BAUD?
```

Setting The System Time and Date

The EMS has an on-board battery-backed time of day clock. This clock keeps track of both time and date. The time and date are used for time stamping the alarm conditions so they may be read back by the user. They may also use this feature to obtain the date and time.

The system time may be set using the command:

```
SYSTEM:TIME <hour>,<minute>,<second>
```

where:

<hour>	ranges from 0 to 23
<minute>	ranges from 0 to 59
<second>	ranges from 0 to 59

The present time may be read using the query:

```
SYSTEM:TIME?
```

The EMS will reply to this query using the format

```
<hour>,<minute>,<second>
```

The system date may be set using the command:

```
SYSTEM:DATE <year>,<month>,<day>
```

where:

<year>	ranges from 1995 to 2020
<month>	ranges from 1 to 12
<day>	ranges from 1 to 31 (may be less than 31 depending on the <month>)

The present date may be read using the query:

```
SYSTEM:DATE?
```

The EMS will reply to this query using the format

```
<year>,<month>,<day>
```

Reading Event Time Stamps

Each alarm condition has an associated time stamp. This time stamp tracks the most recent occurrence of the out-of-tolerance condition. The time stamp indicates the earliest time at which the most recent out-of-tolerance condition was detected.

In general, the time stamps may be read using a query of the form:

```
<attribute>:ALARM:TIME?    -- read the time of the event
<attribute>:ALARM:DATE?    -- read the date of the event
```

Where <attribute> is replaced by a keyword which indicates which attribute's out-of-tolerance time stamp is to be read. The valid queries are:

```
VOLT1:ALARM:TIME?    -- +5V PS voltage alarm
VOLT2:ALARM:TIME?    -- -5.2V PS voltage alarm
VOLT3:ALARM:TIME?    -- -2V PS voltage alarm
VOLT4:ALARM:TIME?    -- +24V PS voltage alarm
VOLT5:ALARM:TIME?    -- -24V PS voltage alarm
VOLT6:ALARM:TIME?    -- +12V PS voltage alarm
VOLT7:ALARM:TIME?    -- -12V PS voltage alarm
CURR1:ALARM:TIME?    -- +5V PS current alarm
CURR2:ALARM:TIME?    -- -5.2V PS current alarm
CURR3:ALARM:TIME?    -- -2V PS current alarm
CURR4:ALARM:TIME?    -- +24V PS current alarm
CURR5:ALARM:TIME?    -- -24V PS current alarm
CURR6:ALARM:TIME?    -- +12V PS current alarm
CURR7:ALARM:TIME?    -- -12V PS current alarm
FREQ1:ALARM:TIME?    -- most recent alarm of any fan
FREQ2:ALARM:TIME?    -- fan #1 alarm
FREQ3:ALARM:TIME?    -- fan #2 alarm
FREQ4:ALARM:TIME?    -- fan #3 alarm
TIME1:ALARM:TIME?    -- power on time alarm
TIME2:ALARM:TIME?    -- cumulative power on time
TIME3:ALARM:TIME?    -- filter service time alarm
TEMP1:ALARM:TIME?    -- slot 0 temp rise alarm
TEMP2:ALARM:TIME?    -- slot 1 temp rise alarm
TEMP3:ALARM:TIME?    -- slot 2 temp rise alarm
TEMP4:ALARM:TIME?    -- slot 3 temp rise alarm
TEMP5:ALARM:TIME?    -- slot 4 temp rise alarm
TEMP6:ALARM:TIME?    -- slot 5 temp rise alarm
TEMP7:ALARM:TIME?    -- slot 6 temp rise alarm
TEMP8:ALARM:TIME?    -- slot 7 temp rise alarm
TEMP9:ALARM:TIME?    -- slot 8 temp rise alarm
TEMP10:ALARM:TIME?    -- slot 9 temp rise alarm
TEMP11:ALARM:TIME?    -- slot 10 temp rise alarm
TEMP12:ALARM:TIME?    -- slot 11 temp rise alarm
TEMP13:ALARM:TIME?    -- slot 12 temp rise alarm
TEMP14:ALARM:TIME?    -- ambient temperature alarm
VXI:SYSFAIL:ALARM:TIME?    -- VXI SYSFAIL* alarm
```

VXI:ACFAIL:ALARM:TIME?	-- VXI ACFAIL* alarm
VXI:IACK1:ALARM:TIME?	-- VXI IACK1 alarm
VXI:IACK2:ALARM:TIME?	-- VXI IACK2 alarm
VXI:IACK3:ALARM:TIME?	-- VXI IACK3 alarm
VXI:IACK4:ALARM:TIME?	-- VXI IACK4 alarm
VXI:IACK5:ALARM:TIME?	-- VXI IACK5 alarm
VXI:IACK6:ALARM:TIME?	-- VXI IACK6 alarm
VXI:IACK7:ALARM:TIME?	-- VXI IACK7 alarm
VXI:BERR:ALARM:TIME?	-- VXI Bus Error alarm

Only the "TIME?" queries are shown above. The "DATE?" queries may be formed by substituting the keyword "DATE" for the keyword "TIME".

The time stamps cannot be set by a command; they can only be queried. The EMS automatically records them into nonvolatile memory whenever an out-of-tolerance condition is detected.

IEEE-488.2 Common Commands

The EMS supports all required IEEE-488.2 commands. In addition, the optional "*OPT?", "*SAV", and "*RCL" commands are all supported. The following paragraphs describe the IEEE-488.2 commands supported by the 1261B EMS.

*IDN? Query

This query requests the instrument to identify itself. The EMS responds to this query with the following reply:

```
Racal Instruments,1261B EMS,0,<firmware revision>
```

This reply indicates the manufacturer ("Racal Instruments"), the model ("1261B EMS"), the serial number (if not available, it is "0"), and the firmware revision. The firmware revision is the only field that may change in the future. The firmware revision is a numeric, floating point value. An example firmware revision is "2.1".

***RST Command**

The *RST command resets the instrument to its power-on default state. These settings are shown in **Table 4-1** of this manual. This command does NOT change the value of SCPI or IEEE-488.2 status registers, event registers, condition registers, or enable registers.

***TST? Query**

The *TST? query initiates an instrument self-test and returns a reply. The reply is a integer numeric value. A value of "0" indicates that the self-test has passed. A non-zero value indicates that one of the commanded self-tests has failed. Consult the "**Performing the Self-Test**" Section of this chapter for a description of the self-test failures and error codes associated.

***CLS Command**

The *CLS command clears the SCPI and IEEE-488.2 defined status event registers. These include the Questionable Voltage Event Register, the Questionable Current Event Register, and so on. This also includes the Standard Event Register (see the *ESR? query description).

***ESE Command**

The *ESE command sets the value of the Standard Event Status Enable Register. The value of this register is logically ANDed with the contents of the Standard Event Status Register (see the *ESR? query description). If any bits of this AND operation are set, then bit 5 of the Status Byte is set. That is:

bit 5 of Status Byte = (bit 0 of ESE AND bit 0 of ESR)
OR
(bit 1 of ESE AND bit 1 of ESR)
OR
(bit 2 of ESE AND bit 2 of ESR)
OR
(bit 3 of ESE AND bit 3 of ESR)
OR
(bit 4 of ESE AND bit 4 of ESR)
OR
(bit 5 of ESE AND bit 5 of ESR)
OR
(bit 6 of ESE AND bit 6 of ESR)
OR
(bit 7 of ESE AND bit 7 of ESR)

where:

ESE is the value as set by the *ESE command

ESR is the value which may be read with *ESR? query

Bit 5 of the Status Byte is also known as the “Event Summary Bit”, or ESB. The *ESE command has the format:

```
*ESE <ESE value>
```

where the “<ESE value>” is an integer numeric value in the range 0 to 255

***ESE? Query**

This query reads the value presently programmed for the “Standard Event Status Enable Register”. This reads the value as programmed by the “*ESE” command.

***ESR? Query**

This query reads the value of the “Standard Event Status Register”. Each bit of this register indicates a true/false status condition. When the bit is set, the condition is TRUE; when the bit is cleared, the condition is FALSE. The bit assignments are defined by the IEEE-488.2 specification. The bit assignments are as follows:

- Bit 0 - Operation Complete. This bit is set when the *OPC command is sent and has been executed.
- Bit 1 - Request Control. This bit is always 0 for the 1261B EMS.
- Bit 2 - Query Error. This bit is set when the EMS parser has detected a query error condition, as defined by the IEEE-488.2 specification.
- Bit 3 - Device Dependent Error. This bit is set when the EMS has detected a Device Dependent error, such as an internal conflict or a self-test failure at power-on.
- Bit 4 - Execution Error. This bit is set when the EMS has attempted to execute a command but the command could not be executed successfully.
- Bit 5 - Command Error. This bit is set when the EMS receives a command it does not recognize.
- Bit 6 - User Request. This bit is always 0 for the 1261B EMS.
- Bit 7 - Power On. This bit is set when the AC line power switch is turned on.

The bits of the Standard Event Status Register are cleared after this query has been executed. The reply to the *ESR? query is a numeric integer value in the range “0” to “255”.

*SRE Command

The *SRE command sets the value of Service Request Enable Register. The value of this register is logically ANDed with the contents of the Status Byte (see the *STB? query description). If any bits of this AND operation are set, bit 6 of the Status Byte is set. That is:

$$\begin{aligned} \text{bit 6 of Status Byte} = & \quad (\text{bit 0 of SRE AND bit 0 of STB}) \\ & \quad \text{OR} \\ & \quad (\text{bit 1 of SRE AND bit 1 of STB}) \\ & \quad \text{OR} \\ & \quad (\text{bit 2 of SRE AND bit 2 of STB}) \\ & \quad \text{OR} \\ & \quad (\text{bit 3 of SRE AND bit 3 of STB}) \\ & \quad \text{OR} \\ & \quad (\text{bit 4 of SRE AND bit 4 of STB}) \\ & \quad \text{OR} \\ & \quad (\text{bit 5 of SRE AND bit 5 of STB}) \\ & \quad \text{OR} \\ & \quad (\text{bit 7 of SRE AND bit 7 of STB}) \end{aligned}$$

where:

SRE is the value as set by the *SRE command

STB is the value of the Status Byte which may be read with *STB? query or by performing a serial poll (VXI read STB command).

Bit 6 of the Status Byte is also known as the "Master Status Summary" bit. When this bit transitions from a 0 to a 1, a VXI Request True interrupt is generated by the EMS. When this bit transitions from a 1 to a 0, a VXI Request False interrupt is generated by the EMS.

The command has the format:

```
*SRE <SRE value>
```

where the "<SRE value>" is an integer numeric value in the range 0 to 255. The value of bit 6 of this register is ignored, since it does not make sense to "enable an interrupt when an interrupt is generated".

*SRE? Query

This query reads the value presently programmed for the "Service Request Enable Register". This reads the value as programmed by the "*SRE" command.

***STB? Query**

This query reads the value of the “Status Byte”. Each bit of this register indicates a true/false status condition. When the bit is set, the condition is TRUE; when the bit is cleared, the condition is FALSE. The bit assignments are defined by the IEEE-488.2 specification. The bit assignments are as follows:

- Bit 0 - Not used. Always returns 0.
- Bit 1 - Not used. Always returns 0.
- Bit 2 - Not used. Always returns 0.
- Bit 3 - Set when the SCPI “Questionable Condition Register” ANDed with the SCPI “Questionable Condition Enable Register” is non-zero.
- Bit 4 - Message Available (MAV). Set when there is a reply in the output buffer to be read.
- Bit 5 - Extended Status Byte (ESB). Set when the IEEE-488.2 Standard Event Register ANDed with the IEEE-488.2 Standard Event Status Register is non-zero.
- Bit 6 - Master Summary Status (MSS). Set when the value of the Status Byte ANDed with the value of the Service Request Enable Register is non-zero. When this bit transitions from a 0 to a 1, a Request True interrupt is generated. When this bit transitions from a 1 to a 0, a Request False interrupt is generated.
- Bit 7 - Not used. Always returns 0.

***OPC Command**

The *OPC command will cause the Operation Complete bit of the Standard Event Status Register (SESR) to be set when the command is executed. This is bit 0 of the SESR. The value of the SESR may be read using the *ESR? query.

The *OPC command has no parameters. The only valid syntax for this command is:

*OPC

*OPC? Query

The *OPC? query causes the EMS to reply with the value of "1" when the query is executed. This query may be used to ensure that all previous commands have been executed so the application program may be sure that tolerances and other attributes have been programmed before continuing.

*RCL Command

The *RCL command will recall the instrument state from nonvolatile memory. The *RCL command may specify a nonvolatile memory location from which to recall the instrument state. That is, both of the following formats are accepted:

```
*RCL  
*RCL <location>
```

If <location> is specified, it must be in the range 0 to 9. If <location> is not specified, it will default to 1.

The *RCL command recalls the following instrument state attributes

Upper and/or Lower Tolerances For:

- Power Supply Voltages
- Power Supply Currents
- Fans' speed
- Ambient Temperature
- VXI Slot Temperature Rise
- VXI IACKn count limits
- VXI BERR count limit
- Elapsed time

Trigger Subsystem Configuration:

- Trigger Delay and Delay Application
- TRIG IN/TRIG OUT connections

Front Panel Display Configuration:

- Front Panel Display On/Off State
- User-Defined Display Text

RS-232 Interface Configuration:

- Baud Rate
- Parity
- Data Bits
- Stop Bits

Note that Status Registers, Condition Registers, Enable Registers, and Event Registers are NOT affected by the *RCL command.

***SAV Command**

The *SAV command will store the present instrument state into nonvolatile memory. The *SAV command may specify a nonvolatile memory location into which the instrument state is saved. That is, both of the following formats are accepted:

```
*SAV
```

```
*SAV <location>
```

If <location> is specified, it must be in the range 0 to 9. If <location> is not specified, the instrument state will be saved into nonvolatile memory location 1. Note that *SAV location 0 is recalled at power-up if the DIP switch SW1-8 is set.

The *SAV command saves all of the attributes described in the *RCL command description into the specified nonvolatile memory location.

***TRG Command**

The *TRG command is required by the IEEE-488.2 specification. This command is accepted but has no effect on the EMS.

***WAI Command**

The *WAI command is required by the IEEE-488.2 specification. This command is accepted but has no effect on the EMS.

Performing The Self Test

The EMS performs a series of self-tests when power is first applied. If any of the self-tests fail, the following message is displayed on the 10 character LED display on the front of the VXI mainframe:

```
Self Test Failed!
```

To determine the cause of this failure, perform one of the following 3 operations:

- Connect an RS-232 terminal to the RS-232 port of the EMS. Cycle power to the EMS by removing and reconnecting the AC power cord. Observe the error messages displayed on the terminal to determine which of the self-tests have failed.
- Connect an RS-232 terminal and keyboard to the RS-232 port of the EMS. Type the command

```
SYST:ERR?
```

on the keyboard. Observe the reply to determine the cause

of the self-test failure. The meaning of the replies to this query are discussed later in this section.

- Turn VXI mainframe power on. After the resource manager program has executed (MXI/VXI and embedded computer interfaces), or after a five second delay (GPIB/VXI slot 0 interface), send the following command to the EMS over the VXIbus:

```
SYST:ERR?
```

Read the reply to determine the cause of the self-test failure. The meaning of the replies to this query are discussed later in this section.

The “Self Test Failed!” message will continually be displayed until it is cleared. This message may be cleared using the following command:

```
DISP:TEXT:CLEAR
```

The self-tests may also be initiated with an ASCII command over either the RS-232 or the VXIbus interface. The command:

```
*TST?
```

initiates the self-test. The self-test will complete after approximately 3 seconds. Upon completion of the self-test, the result may be read via the VXIbus (the result will automatically be sent over the RS-232 interface if the command was received on the RS-232 interface).

The result of the self-test will be one of the following:

- 0 The self-test has passed
- 1 The checksum of the ROM which contains the firmware does not match the checksum stored in the ROM itself.
- 2 The EEPROM checksum does not match the checksum stored in the EEPROM itself; the EEPROM is possibly corrupt.
- 3 One of the VXI mainframe sensors routed to the EMS's A/D converter has failed. The measured value on one of the sensors has measured extremely high, indicating that the sensor is disconnected. The sensor(s) at fault is indicated in the reply to the “SYST:ERR?” query.

- 4 The EMS programmable interrupt timer has failed its self test.
- 5 One section of the EEPROM has failed its verification. Some data in the EEPROM may be corrupt.
- 6 The real-time clock has failed its self-test. Date and Time functions will not work properly. Time stamps for alarm conditions will not be recorded properly.

If any non-zero error code is returned, a description of the failure is placed on the error queue. The cause of the error may be read using the command:

```
SYST:ERR?
```

This command may be sent over the RS-232 or the VXIbus interface. The EMS will reply with an error message with the form:

```
-330,"Self-test failed;<self-test failure description>"
```

The <self-test failure description>s, and their meanings, are described below:

```
ROM checksum failed (is XXXX, s/b YYYY)
```

This error is returned when the ROM checksum has failed (*TST? returns -1). The computed checksum is shown as four hexadecimal digits, represented by XXXX. The stored checksum is shown as four hexadecimal digits, represented by YYYY.

```
PS Voltage Sensors: +5V -5.2V -2V +24V -24V +12V -12V
```

This error is returned when the Power Supply voltage sensors for one or more of the power supplies has failed. All seven power supplies are shown in this example. Only the failing supplies will be shown when this error occurs. This message may be returned if the *TST? command returns a value of -3.

```
PS Current Sensors: +5V -5.2V -2V +24V -24V +12V -12V
```

This error is returned when the Power Supply current sensors for one or more of the power supplies has failed. All seven power supplies are shown in this example. Only the failing supplies will be shown when this error occurs. This message may be returned if the *TST? command returns a value of -3.

```
Fan Speed Sensors: Fan#1 Fan#2 Fan#3
```

This error is returned when the fan speed monitor sensors for one or more of the fans has failed. All three fans are shown in this example. Only the failing fan(s) will be shown when this error occurs. This message may be returned if the *TST? command returns a value of -3.

Ambient Temperature Sensor

This error is returned when the ambient temperature sensor has failed. The message may be returned if the *TST? command returns a value of -3.

Slot Temperature Sensors (Slots): 0 1 2 3 4 5 6 7 8 9 10 11 12

This error is returned when one or more of the slot temperature sensors has failed. This example shows all thirteen of the slot temperature sensors. Only the failing sensors will be shown when this error occurs. This message may be returned if the *TST? command returns a value of -3.

Microcontroller P.I.T failed

This error is returned when the EMS's Programmable Interrupt Timer test has failed. This message will be returned if the *TST? command returns a value of -4.

EEPROM header corrupt (XXXXXXXX)

This error is returned when the header (first 4 bytes) of the EEPROM do not match the expected fixed pattern of AAAA5555 hexadecimal. The actual value read from the EEPROM is shown as 8 hexadecimal digits enclosed in parentheses. This error may be returned if the *TST? command returns a value of -5.

EEPROM Alarm Data Corrupt (Address XXXX)

This error is returned when one of the alarm time-stamps in the EEPROM does not have a valid checksum. This indicates that the particular time stamp is corrupted. The address within the 8K EEPROM is shown as four hexadecimal digits. This error may be returned if the *TST? command returns a value of -5.

EEPROM state X read fail

This error is returned when the attempt to read the data for state X (X = 0 to 9) has failed. This indicates that the stored instrument state location MAY be corrupt. This error may be returned if the *TST? command returns a value of -5.

EEPROM state X checksum fail

This error is returned when the checksum stored for the instrument state does not match the computed checksum for that state. This indicates that the stored instrument state MAY be corrupt. This error may be returned if the *TST? command returns a value of -5. The X will be replaced by the state that was found to be corrupt (X = 0 to 9).

EEPROM read failure

This error is returned when the EEPROM indicates that it is busy writing data for more than 40 milliseconds. This indicates a general EEPROM failure. This error may be returned if the *TST? command returns a value of -5.

Time-of-day real-time clock failed

This error is returned when the real-time clock on the EMS does not advance after a minimum of 1.2 seconds. This error may be returned if the *TST? command returns a value of -6.

Power-on time real-time clock failed

This error indicates that the power-on time real-time clock on the EMS does not advance after a minimum of 1.2 seconds. This error may be returned if the *TST? command returns a value of -6.

The following self-tests are NOT performed when VXI mainframe power is NOT applied:

EEPROM tests

real-time clock tests

This page was left intentionally blank.

SCPI COMMAND REFERENCE

What's In This Chapter

This chapter contains reference information for programming the Model 1261B Enhanced Monitoring System (EMS). Standard Commands For Programmable Instruments (SCPI) convention rules and syntax are explained in detail. **Table 5-1** lists all SCPI commands used for programming the EMS. The command summary for each SCPI model is also included in this chapter.

This chapter teaches you how to use SCPI commands to control functions, modes, waveforms and other aspects of the instrument. Prior understanding of SCPI programming is necessary for low level programming of the EMS.

Introduction To SCPI Language

Commands to program the instrument over the VXIbus and RS-232 interfaces are defined by the SCPI 1994.0 standard. The SCPI standard defines a common language protocol. It goes one step further than IEEE-STD-488.2 and defines a standard set of commands to control every programmable aspect of the instrument. It also defines the format of command parameters and the format of values returned by the instrument.

SCPI is an ASCII-based instrument command language designed for test and measurement instruments. SCPI commands are based on a hierarchical structure known as a tree system. In this system, associated commands are grouped together under a common mode or root, thus forming subsystems. Throughout this chapter, the following conventions are used for SCPI command syntax.

Square Brackets ([])	Enclose optional keywords or parameters
Braces ({ })	Enclose parameters within a command string
Triangle Brackets (< >)	Substitute a value for the enclosed parameter
Vertical Bar ()	Separate multiple parameter

choices

Bold Typeface Letters Designate factory default values

Part of the DISPlay subsystem is shown below to illustrate the tree system:

```
[:]DISPlay
    [:WINDow]
        :TEXT
            :CLEar
            [:DATA] <string>
            :STATE OFF|ON
```

DISPlay is the root keyword of the command, WINDow is the optional second level keyword, TEXT is the third level keyword. CLEar, DATA, and STATE are fourth level keywords. A colon (:) separates a command keyword from a lower level keyword.

Command Keyword Long Form and Short Form

Each keyword defined by SCPI has both a long form and a short form. The long form is formed by using all letters shown in the keyword. The short form is formed by using only the uppercase letters shown in the keyword.

For example, the DISPlay keyword may be specified by either of the following:

```
DISP
DISPLAY
```

No other form can be used to specify the keyword. The keyword "DISPL" may NOT be used.

Case Sensitivity

Command keywords are NOT case sensitive. Command parameters are NOT case sensitive, unless the parameter is string data enclosed in quotes.

For example, the following commands are all equivalent:

```
DISPLAY
Display
DiSpLaY
disPLAY
display
```

Optional Keywords Command keywords enclosed in square brackets are optional. For example, all of the following commands are valid and equivalent:

```
DISPLAY:WINDOW:TEXT:DATA "Hello"  
DISPLAY:TEXT:DATA "Hello"  
DISPLAY:WINDOW:TEXT "Hello"  
DISPLAY:TEXT "Hello"
```

A colon (:) is used to separate a command keyword from a lower level keyword as shown below:

```
DISP:WIND:TEXT:STATE ON
```

A semicolon (;) is used to separate commands within the same subsystem, and can also minimize typing. For example, sending the following command string:

```
DISP:TEXT "Example Text" ; STATE ON
```

is the same as sending the following two commands:

```
DISP:TEXT "Example Text"  
DISP:TEXT:STATE ON
```

Use the colon and semicolon to link commands from different subsystems. For example, in the following command string, an error is generated if both the colon and the semicolon are not used.

```
DISP:TEXT:STATE ON;:SYSTEM:ERR?
```

Multiple Identical Capabilities and Keyword Suffixes

In several places in the EMS, there are nearly identical measuring capabilities across multiple instances of a monitored attribute. For example, the voltage from 7 different power supplies can be read. The base keyword used to measure the power supply voltage is shown as:

```
MEASure:VOLTage[<N>]? (N = 1 - 7)
```

This represents eight different keywords:

MEASure:VOLTage?	-- read +5V Power Supply
MEASure:VOLTage1?	-- read +5V Power Supply
MEASure:VOLTage2?	-- read -5.2V Power Supply
MEASure:VOLTage3?	-- read -2V Power Supply
MEASure:VOLTage4?	-- read +24V Power Supply
MEASure:VOLTage5?	-- read -24V Power Supply
MEASure:VOLTage6?	-- read +12V Power Supply
MEASure:VOLTage7?	-- read -12V Power Supply

Each of these has a long form and a short form. Thus

```
MEAS:VOLTAGE2?
MEAS:VOLT2?
```

are equivalent.

Omitting the keyword suffix selects the same capability as specifying the suffix of 1. This means that:

```
MEAS:VOLTage?
MEAS:VOLTage1?
```

are equivalent.

The MIN, MAX, and DEF Parameters

Substitute MINimum, MAXimum, or DEFault in place of a numeric parameter for most commands. For example, the following command:

```
:VOLTAGE3:RANGE:UPPER MIN
```

sets the upper voltage range for the -2V power supply monitor to its minimum programmable value. The command:

```
:VOLTAGE3:RANGE:UPPER DEF
```

sets the upper voltage range for the -2V power supply monitor to its default, power-on value.

The MINimum, MAXimum, and DEFault keywords are accepted for all SENSE:<Attribute>:RANGE commands and the VXI:CONF:MON:TRIG:DELAY command.

Querying Parameter Setting

Query the current value of most parameters by adding a question mark (?) to the command. For example, the following command sets the trigger delay to 0.5 seconds:

```
VXI:CONF:MON:TRIG:DELAY 0.5
```

Query the trigger delay by executing:

```
VXI:CONF:MON:TRIG:DELAY?
```

Query Response Format

The response to a query depends on the command sent to the instrument to generate the query response. In general, a response to a query contains present values or settings of the EMS. Commands that set values can be queried about their present value of the setting. Commands that set modes of operation can be queried about their present mode setting.

SCPI Command Terminator

A command string sent to the EMS must be terminated with a one of the following:

- 1) An ASCII linefeed character: (decimal 10, hex 0A, 'C' char '\n').
- 2) The last character with the END bit set to 1.
- 3) An ASCII linefeed character with the END bit set to 1.

The END bit for a VXI instrument is analogous to the GPIB EOI line. The END bit is sent along with each character using the Word Serial Byte Available command. GPIB/VXI slot 0 controllers translate the GPIB EOI line to VXIbus protocol, which sets the END bit to identify the last character of a command.

Over the RS-232 interface, there is no EOI line. Therefore, ALL commands transmitted over the RS-232 interface must be terminated with the ASCII

IEEE-STD-488.2 Common Commands

The IEEE-STD-488.2 standard defines a set of common commands that perform functions like reset, trigger and status operations. Common commands begin with an asterisk (*), are four to five characters in length, and may include parameters. The command keyword is separated from the first parameter by a blank space. Use a semicolon (;) to separate multiple commands as shown below:

```
*RST; *STB?; *IDN?
```

SCPI Parameter Type

The SCPI language defines several different data formats to be used in program messages and response messages.

Numeric Parameters

Commands that require numeric parameters will accept all commonly used decimal representations of numbers including optional signs, decimal points, and scientific notation. Special values for numeric parameters like MINimum, MAXimum, and DEFault are also accepted.

Engineering unit suffixes with numeric parameters (e.g., mV, KV, mA, KHz) can also be sent. If only specific numeric values are accepted, the function generator will ignore values which are not accepted and will generate an error message. The following command is an example of a command that uses a numeric parameter:

```
SENSE:VOLT1:RANGE:UPPER 5.75
```

Discrete Parameters

Discrete parameters are used to program settings that have a limited number of values (e.g., trigger delay is applied to INPut or OUTput or NONE). They have short and long form command keywords. Upper and lower case letters can be mixed. Query responses always return the short form in all upper case letters. The following command uses discrete parameters:

```
:VXI:CONF:MON:DELAY:STATE {INPut | OUTput | NONE}
```

Boolean Parameters

Boolean parameters represent a single binary condition that is either true or false. The EMS accepts "OFF" or "0" for a false condition. The EMS accepts "ON" or "1" for a true condition. The instrument always returns "0" or "1" when a boolean setting is queried. The following command uses a boolean parameter:

```
:DISPLAY:TEXT:STATE { OFF | ON | 0 | 1 }
```

SCPI Command Summary

Table 5-1 summarizes the complete SCPI command tree available to program the EMS. Refer to section 4 in this manual for more complete details on each command.

Table 5-1. VXibus Model 1261B EMS SCPI Commands List Summary

Keyword	Parameter Form (Default in Bold)	SCPI 1994.0	Notes
:SYSTem	Confirmed		
:ERRor ?		Confirmed	(Query only)
:VERsion?		Confirmed	(Query only)
:COMMunicate		Confirmed	
:SERial		Confirmed	
[:RECeive]		Confirmed	
:BAUD	1200 2400 4800 9600	Confirmed	Combinations of Parity/Data/Stop Bits which are NOT allowed:
:BITS	7 8	Confirmed	
:SBITs	1 2	Confirmed	
:PARity		Confirmed	
[:TYPE]	EVEN ODD NONE	Confirmed	
:TRANsmit		Confirmed	
:AUTO		Confirmed	Programming either the TRANSMIT or the RECEIVE direction programs BOTH directions
:BAUD	1200 2400 4800 9600	Confirmed	
:BITS	7 8	Confirmed	
:SBITs	1 2	Confirmed	
:TIME	<hour>, <minute>, <second>	Confirmed	ranges: 0 - 23, 0 - 59, 0 - 59
:DATE	<year>, <month>, <day>	Confirmed	ranges: 1995 - 2120, 1 - 12, 1 - 31
:MEASure	Confirmed		
:VOLTage[<N>]?		Confirmed*	<N> = 1 - 7 (Query only)
:CURRent[<N>]?		Confirmed*	<N> = 1 - 7 (Query only)
:FREQuency[<N>]?		Confirmed*	<N> = 1 - 4 (Query only)
:TIME[<N>]?		Not Confirmed	<N> = 1 - 3 (Query only)
:TEMPerature[<N>]?		Confirmed*	<N> = 1 - 14 (or 1 - 27) (Query only)
:VXI		Not Confirmed	
:ACFail?		Not Confirmed	(Query only)
:ASTRobe?		Not Confirmed	(Query only)
:SYSFail?		Not Confirmed	(Query only)
:STATus	Confirmed		
:PRESet		Confirmed	(Command only)
:OPERation		Confirmed	Command has no effect
[:EVENT]?		Confirmed	Command has no effect (Query only)
:CONDition?		Confirmed	Command has no effect (Query only)
:ENABle	(0;0;32767)	Confirmed	Command has no effect
:QUESTionable		Confirmed	
[:EVENT]?		Confirmed	(Query only)
:CONDition?		Confirmed	(Query only)
:ENABle	(0;0;32767)	Confirmed	
:VOLTage		Confirmed	
[:EVENT]?		Confirmed	(Query only)
:CONDition?		Confirmed	(Query only)
:ENABle	(0;0;32767)	Confirmed	Meaningful range is 0 to 127
:CURRent		Confirmed	
[:EVENT]?		Confirmed	(Query only)
:CONDition?		Confirmed	(Query only)
:ENABle	(0;0;32767)	Confirmed	Meaningful range is 0 to 127
:TEMPerature		Confirmed	
[:EVENT]?		Confirmed	(Query only)
:CONDition?		Confirmed	(Query only)
:ENABle	(0;0;32767)	Confirmed	Meaningful range is 0 to 16383
:FREQuency		Confirmed	
[:EVENT]?		Confirmed	(Query only)
:CONDition?		Confirmed	(Query only)
:ENABle	(0;0;32767)	Confirmed	Meaningful range is 0 to 15
:TIME		Confirmed	
[:EVENT]?		Confirmed	(Query only)
:CONDition?		Confirmed	(Query only)
:ENABle	(0;0;32767)	Confirmed	Meaningful range is 0 to 7

Keyword	Parameter Form (Default in Bold)	SCPI 1994.0	Notes
:VXI		Not Confirmed	
[:EVENT]?		Not Confirmed	(Query only)
:CONDition?		Not Confirmed	(Query only)
:ENABle	(0;0;32767)	Not Confirmed	Meaningful range is 0 to 1024
[:SENSE]	Confirmed		
:VOLTage[<N>]		Confirmed	N = 1 - 7
[:DC]		Confirmed	
:RANGe		Confirmed	
[:UPPer]	<voltage as a real number>**	Confirmed	set most positive voltage monitor limit
:LOWer	<voltage as a real number>**	Confirmed	set most negative voltage monitor limit
:ALARm		Not Confirmed	
[:TIME]?		Not Confirmed	(Query only)
:DATE?		Not Confirmed	(Query only)
:CURRent[<N>]		Confirmed	N = 1 - 7
[:DC]		Confirmed	
:RANGe		Confirmed	
[:UPPer]	<current as a real number>**	Confirmed	set current monitor limit
:LOWer	<current as a real number>**	Confirmed	may be specified but is ignored
:ALARm		Not Confirmed	
[:TIME]?		Not Confirmed	(Query only)
:DATE?		Not Confirmed	(Query only)
:FREQuency[<N>]		Confirmed	N = 1 - 4, 1 = all 3 fans
:RANGe		Confirmed	
[:UPPer]	<frequency as a real number (RPM)>**	Confirmed	set maximum frequency limit
:LOWer	<frequency as a real number (RPM)>**	Confirmed	set minimum frequency limit
:ALARm		Not Confirmed	
[:TIME]?		Not Confirmed	(Query only)
:DATE?		Not Confirmed	(Query only)
:TIME[<N>]		Not Confirmed	N = 1 - 3
:RANGe		Not Confirmed	
[:UPPer]	<time as a real number (seconds)>**	Not Confirmed	set maximum time limit
:LOWer	<time as a real number (seconds)>**	Not Confirmed	may be specified but is ignored
:ALARm		Not Confirmed	
[:TIME]?		Not Confirmed	(Query only)
:DATE?		Not Confirmed	(Query only)
:TEMPerature[<N>]		Not Confirmed	N = 1 - 14 (or 1- 27 if option installed)
:RANGe		Not Confirmed	
[:UPPer]	<upper Temperature>**	Not Confirmed	set maximum temperature/temp rise
:UPPer?			
:LOWer	<lower Temperature>**	Not Confirmed	may be specified but is ignored
:LOWer?			
:ALARm		Not Confirmed	
[:TIME]?		Not Confirmed	(Query only)
:DATE?		Not Confirmed	(Query only)
:MODE 0/1			
:MODE?			
:VXI		Not Confirmed	
:SYSFail		Not Confirmed	
:ALARm		Not Confirmed	
[:TIME]?		Not Confirmed	(Query only)
:DATE?		Not Confirmed	(Query only)
:ACFail		Not Confirmed	
:ALARm		Not Confirmed	
[:TIME]?		Not Confirmed	(Query only)
:DATE?		Not Confirmed	(Query only)
:IACK<N>		Not Confirmed	N = 1 to 7
:COUNT?		Not Confirmed	(Query only)
:LIMit (0;0;255)		Not Confirmed	
:CLEar		Not Confirmed	(Command only)
:ALARm		Not Confirmed	
[:TIME]?		Not Confirmed	(Query only)
:DATE?		Not Confirmed	(Query only)
:BERR		Not Confirmed	
:COUNT?		Not Confirmed	(Query only)
:LIMit (0;0;255)		Not Confirmed	
:CLEar		Not Confirmed	(Command only)
:ALARm		Not Confirmed	
[:TIME]?		Not Confirmed	(Query only)
:DATE?		Not Confirmed	(Query only)

Reviser 6/14/00

Keyword	Parameter Form (Default in Bold)	SCPI 1994.0	Notes
:VXI	Confirmed		
:CONFigure		Confirmed	
:MONitor		Not Confirmed	
[:TRIGger]		Not Confirmed	
[:INPut]	TTLTRG0 TTLTRG1 TTLTRG2 TTLTRG3 TTLTRG4 TTLTRG5 TTLTRG6 TTLTRG7 NONE	Not Confirmed	
:OUTput	TTLTRG0 TTLTRG1 TTLTRG2 TTLTRG3 TTLTRG4 TTLTRG5 TTLTRG6 TTLTRG7 NONE INPut	Not Confirmed	
:DELay		Not Confirmed	
[:TIME]	(0; 0; 1.04857596875)	Not Confirmed	
:STATe	INPut OUTput OFF	Not Confirmed	
:DISPlay		Confirmed	
[:WINDow]		Confirmed	
:TEXT		Confirmed	
:CLEar		Confirmed	
[:DATA]	<string data>	Confirmed	enclose <string data> in quotes
:STATe	OFF ON 0 1	Confirmed	
Common Commands	Parameter Form (Default; Min; Max)	IEEE-488.2	Notes
*CLS		Confirmed	
*ESE	(0;0;255)	Confirmed	
*ESE?		Confirmed	
*ESR?		Confirmed	
*IDN?		Confirmed	
*OPC		Confirmed	
*OPC?		Confirmed	
*RCL	[0 1 2 3 4 5 6 7 8 9]	Confirmed	
*RST		Confirmed	
*SAV	[0 1 2 3 4 5 6 7 8 9]	Confirmed	
*SRE	(0;0;255)	Confirmed	
*SRE?		Confirmed	
*STB?		Confirmed	
*TRG		Confirmed	command has no effect
*TST?		Confirmed	
*WAI		Confirmed	command has no effect

Notes:

* The limits and default values depend upon which power supply is being measured. Consult **Table 5-2**.

** Although these MEASure commands are identified in SCPI version 1994.0, this implementation does NOT accept either the expected value or the resolution as a parameter. The MEASure commands accept NO parameters as implemented by the Enhanced Monitoring System.

Command Parameter Limits

The parameter limits for the numeric commands are shown in Table 5-2.

Table 5-2, Defaults, Minima and Maxima

Command	Default	Minimum	Maximum	Notes
SENSE:VOLT1:RANGE:UPPER	5.4	5.0	40.0	+5V PS voltage upper tolerance
SENSE:VOLT1:RANGE:LOWER	4.6	0.0	5.0	+5V PS voltage lower tolerance
SENSE:VOLT2:RANGE:UPPER	-4.8	-5.2	0.0	-5.2V PS voltage upper tolerance
SENSE:VOLT2:RANGE:LOWER	-5.6	-40.0	-5.2	-5.2V PS voltage lower tolerance
SENSE:VOLT3:RANGE:UPPER	-1.8	-2.0	0.0	-2V PS voltage upper tolerance
SENSE:VOLT3:RANGE:LOWER	-2.2	-16.0	-2.0	-2V PS voltage lower tolerance
SENSE:VOLT4:RANGE:UPPER	25.9	24.0	100.0	+24V PS voltage upper tolerance
SENSE:VOLT4:RANGE:LOWER	22.1	0.0	24.0	+24V PS voltage lower tolerance
SENSE:VOLT5:RANGE:UPPER	-22.1	-24.0	0.0	-24V PS voltage upper tolerance
SENSE:VOLT5:RANGE:LOWER	-25.9	-100.0	-24.0	-24V PS voltage lower tolerance
SENSE:VOLT6:RANGE:UPPER	12.9	12.0	100.0	+12V PS voltage upper tolerance
SENSE:VOLT6:RANGE:LOWER	11.1	0.0	12.0	+12V PS voltage lower tolerance
SENSE:VOLT7:RANGE:UPPER	-11.1	-12.0	0.0	-12V PS voltage upper tolerance
SENSE:VOLT7:RANGE:LOWER	-12.9	-100.0	-12.0	-12V PS voltage lower tolerance
SENSE:CURR1:RANGE:UPPER	85.6	0.0	100.0	+5V PS current upper tolerance
SENSE:CURR2:RANGE:UPPER	64.2	0.0	75.0	-5.2V PS current upper tolerance
SENSE:CURR3:RANGE:UPPER	32.1	0.0	37.5	-2V PS current upper tolerance
SENSE:CURR4:RANGE:UPPER	12.9	0.0	15.0	+24V PS current upper tolerance
SENSE:CURR5:RANGE:UPPER	12.9	0.0	15.0	-24V PS current upper tolerance
SENSE:CURR6:RANGE:UPPER	13.9	0.0	16.3	+12V PS current upper tolerance
SENSE:CURR7:RANGE:UPPER	13.9	0.0	16.3	-12V PS current upper tolerance
SENSE:FREQ:RANGE:UPPER	5200.0	2000.0	7650.0	All Fans, upper RPM tolerance
SENSE:FREQ:RANGE:LOWER	2000.0	500.0	7650.0	All Fans, lower RPM tolerance
SENSE:TEMP14:RANGE:UPPER	55.0	0.0	140.0	Ambient temperature upper tol
SENSE:TEMP<X>:RANGE:UPPER	30.0	0.0	140.0	VXI slot temp rise tol. <X> = 1 to 13
SENSE:TEMP<X>:RANGE:UPPER	55.0	0.0	140.0	VXI slot temp Absolute. <X> = 15 to 27
SENSE:TIME1:RANGE:UPPER	31536000 (365 days)	0.0	125 years	Power-On elapsed time limit
SENSE:TIME2:RANGE:UPPER	157680000 (5 x 365 days)	0.0	125 years	Cumulative power-on time limit
SENSE:TIME3:RANGE:UPPER	15552000 (180 days)	0.0	125 years	Filter service power-on time limit
SENSE:VXI:IACK<X>:LIMIT	0	0	255	IACKn limit (<X> = 1 to 7)
SENSE:VXI:BERR:LIMIT	0	0	255	VXI Bus Error limit
VXI:CONF:MON:TRIG:DELAY:TIME	0.0	0.0	1048575968.75 (nanoseconds)	Trigger Delay time resolution = 31.25 nanosecond

Device Specific Commands

The 1261B EMS conforms to the 1994.0 version of the SCPI standard. Some of the commands used are not included in the 1994.0 version. However, these commands are designed with the SCPI standard in mind and they follow all of the command syntax rules defined by the standard. **Table 5-1** lists all device-specific commands that were designed specifically for the EMS as “Not Confirmed” to the 1994.0 SCPI version.

This page was left intentionally blank.

UNDERSTANDING THE 1261B

Overview

The 1261B Mainframe consists of the following major functional blocks.

- Power Supply
- Backplane
- Cooling System
- Monitoring System

Figure 6-1 shows the functional block diagram of the 1261B Mainframe

Power Supply

The power supply accepts power from the AC mains and converts it to DC to power the following:

VXI modules installed into the backplane

- Backplane terminations and daisy chaining logic
- Module Cooling Fans
- System Monitoring Module
- Temperature Monitor Module
- • Front Panel Display

Power Supply Interconnection

Power is supplied to the backplane through board-to-board connector P52 eliminating any wiring and sub-backplane interconnect boards. This design reduces the path impedance between the supply and the VXI modules receiving power, which results in improved dynamic current performance. See **Appendix A** for specifications.

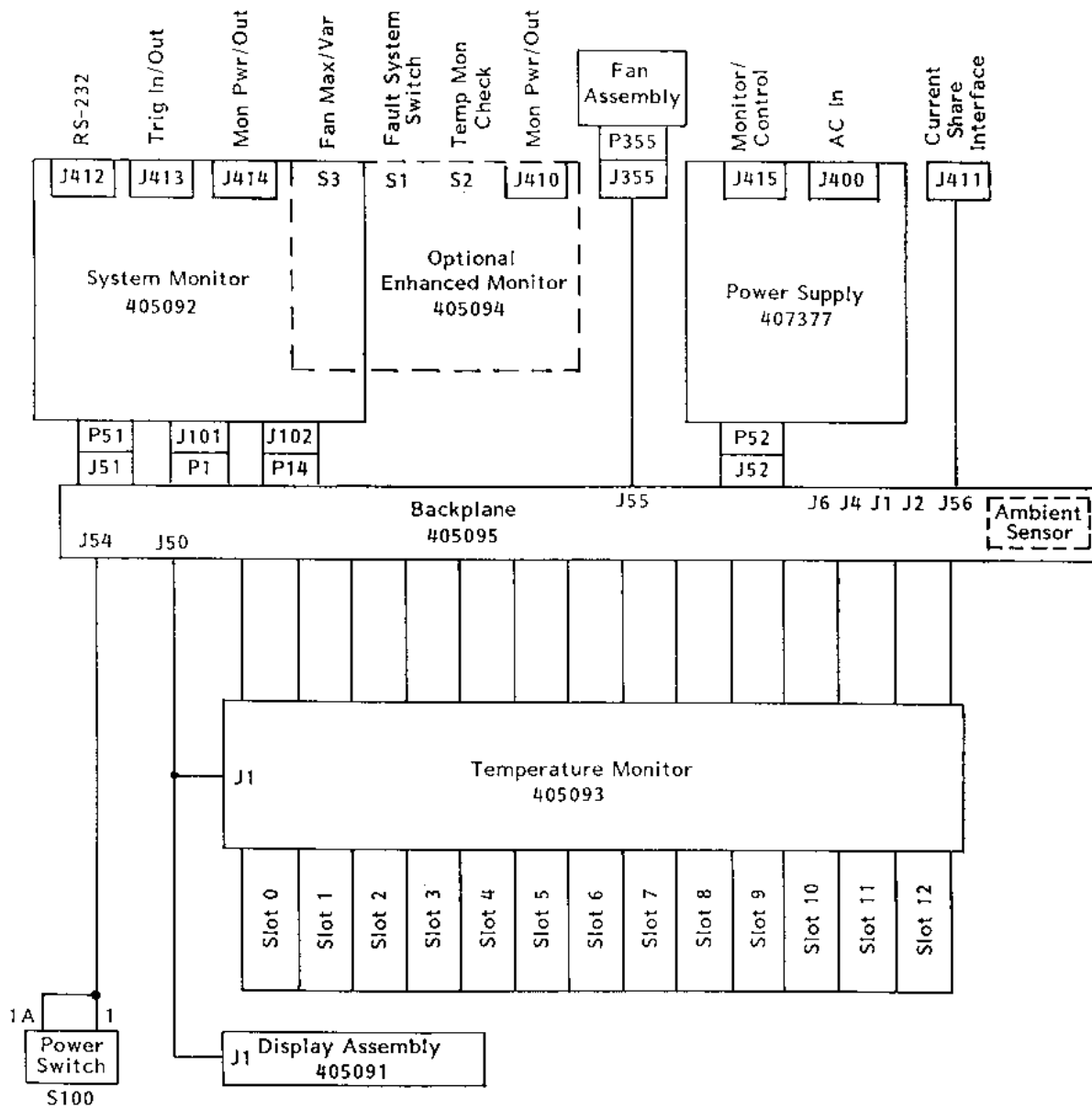

Figure 6-1, Functional Block Diagram For 1261B Chassis

Power Supply Protections

The seven VXIbus power supply outputs are protected for:

Over-voltage

- Over-current
- Over-temperature

The AC input of the power supply includes protections for:

- Input current limit (15 Amps)
- Over-temperature

See **Appendix A** for specification details pertaining to the above protections. If any of the above protections are active, the power supply is shutdown. This means it has, effectively, turned itself off to protect the system. The Power On/Standby switch or the Remote Inhibit input must be cycled to turn the mainframe back on. Refer to **Powering On The Mainframe** and **Using Remote Power On/Standby Switching** in **Chapter 3**.

Backplane

The Backplane serves several functions

- Rigid mechanical interface which accommodates a lifetime of insertions of VXI modules and the plug-in power supply.
- Supplies DC voltages and currents to modules.
- Connects the VME communications interface across P1 and P2 from slot 0 to slot 12.
- Connects the VXI extensions across P2 rows a and c from slot 0 to slot 12.
- Connects the monitoring system module, temperature monitor board, display board, Power On/Standby switch, and module cooling fans with the power supply.

Backplane Interconnections

The Power On/Standby switch (S100) connects to the backplane through a polarized locking wire-to-board header at J54.

The front panel display module and the temperature monitor board connect to the backplane through a 24-pin ribbon cable IDC header at J50.

The module cooling fans connect to the backplane through a polarized locking wire-to-board header at J56.

The power supply mates with the backplane through board-to-board connector J52.

The monitoring system module mates with the backplane through a board-to-board connector at J51.

Cooling System

The Module Fan assembly, located at the bottom rear of the mainframe, houses three cooling fans. The speed of these fans is controlled to maintain a temperature rise of $\leq 10^{\circ}\text{C}$ across any module slot in the mainframe. In high ambient temperature conditions of $\geq 40^{\circ}\text{C}$, the fans shall run full speed.

Rack Mount Cooling System

Module cooling air enters at the bottom sides of the 1261B Rack Mount mainframe and is filtered as it is drawn through the fan assembly.

The incoming air is forced downward into a pressurized plenum below the VXI modules. The high pressure in the plenum forces the air up through a metered plate into the VXI modules. The air passing over components in the modules absorbs heat and exits at the top of the module.

The 1261B Rack Mount mainframe exhausts module cooling air at the rear of the mainframe.

Bench Top Cooling System

Filtered air enters at the bottom rear of the 1261B Bench Top mainframe through the fan assembly.

The incoming air is forced downward into a pressurized plenum below the VXI modules. The high pressure in the plenum forces the air up through a metered plate into the VXI modules. The air passing over components in the modules absorbs heat and exits at the top of the module.

Cooling air is exhausted through the top of the mainframe in the 1261B Bench Top mainframe.

Cooling The Power Supply

The power supply assembly contains a speed controlled fan for its own internal cooling. Filtered air enters through the one side of the mainframe and exits at the opposite side after passing through the power supply.

Standard Monitoring System

The Standard Monitoring System (SMS) performs temperature monitoring on each slot, fan speed sensing and control, power supply voltage and current monitoring. System status is reported via a front panel annunciator for Voltage, Current, Airflow and Temperature alarm conditions.

SMS Fan Speed Monitor

A TTL pulse train at the speed (RPM) of each fan is output to rear panel Monitor Connector J410. The fans output 2 pulses per revolution.

The front panel AIRFLOW LED is green under normal conditions and red during a fault. A fault is indicated when the fan speed is < 15 Hz or > 300 Hz.

SMS Fan Speed Control

The speed of the module cooling fans is controlled by either the slot with the highest absolute temperature or the highest temperature rise.

If the absolute temperature of any slot exceeds +40°, the fans operate at full speed. If the temperature rise across any module slot exceeds 10°C, the fans operate at full speed.

SMS Fan Speed Switch

Switch S3 mounted on the SMS rear panel allows user to select between **maximum** fan speed or **variable** fan speed.

SMS Temperature Monitor

The exhaust air temperature of each slot is measured by 13 passive thermistors. An additional thermistor monitors the intake air temperature.

The absolute temperature of each thermistor is measured in DC volts. The non-linear DC voltage generated by each thermistor is made linear by using an A/D converter, PROM look up table and D/A converter.

A DC voltage proportional to highest temperature rise of any slot ($0.1V/^{\circ}C$) is made output to the rear panel monitor connector J410. A voltage proportional to the intake air temperature ($0.1V/^{\circ}C$) is also output to this connector.

The TEMP LED indicates a fault (red) when the highest slot **temperature** is $> 75^{\circ}C$ or the highest slot **temperature rise** is $> 20^{\circ}C$.

SMS Voltage Monitoring

All of the VXI voltages of the 1261B are monitored. If the absolute voltage value of any of these are not within +10%, -8.75% of the nominal voltage, the front panel VOLTAGE LED shall indicate a fault (red).

When the front panel Power On/Standby switch is in the Standby (off) position, the SMS shall indicate a fault when any VXI voltage is > 0.5 VDC.

SMS Current Monitoring

The front panel CURRENT LED indicates a fault (red) if the current drawn from any power supply output exceeds the rated peak output current by more than 7%. The CURRENT LED is green when no fault is present.

Enhanced System Monitor (EMS)

The Enhanced Monitoring System adds a fully VXIbus 1.4 compliant message-based interface, alpha numeric display, individual VXIbus voltage and slot temperature reading, TTL trigger in/outputs with programmable delay, and monitoring of key VXI backplane signals (AS*, ACFAIL*, SYSRESET*).

Refer to **Figure 6-2 Enhanced Monitoring System Module Block Diagram** and the description below.

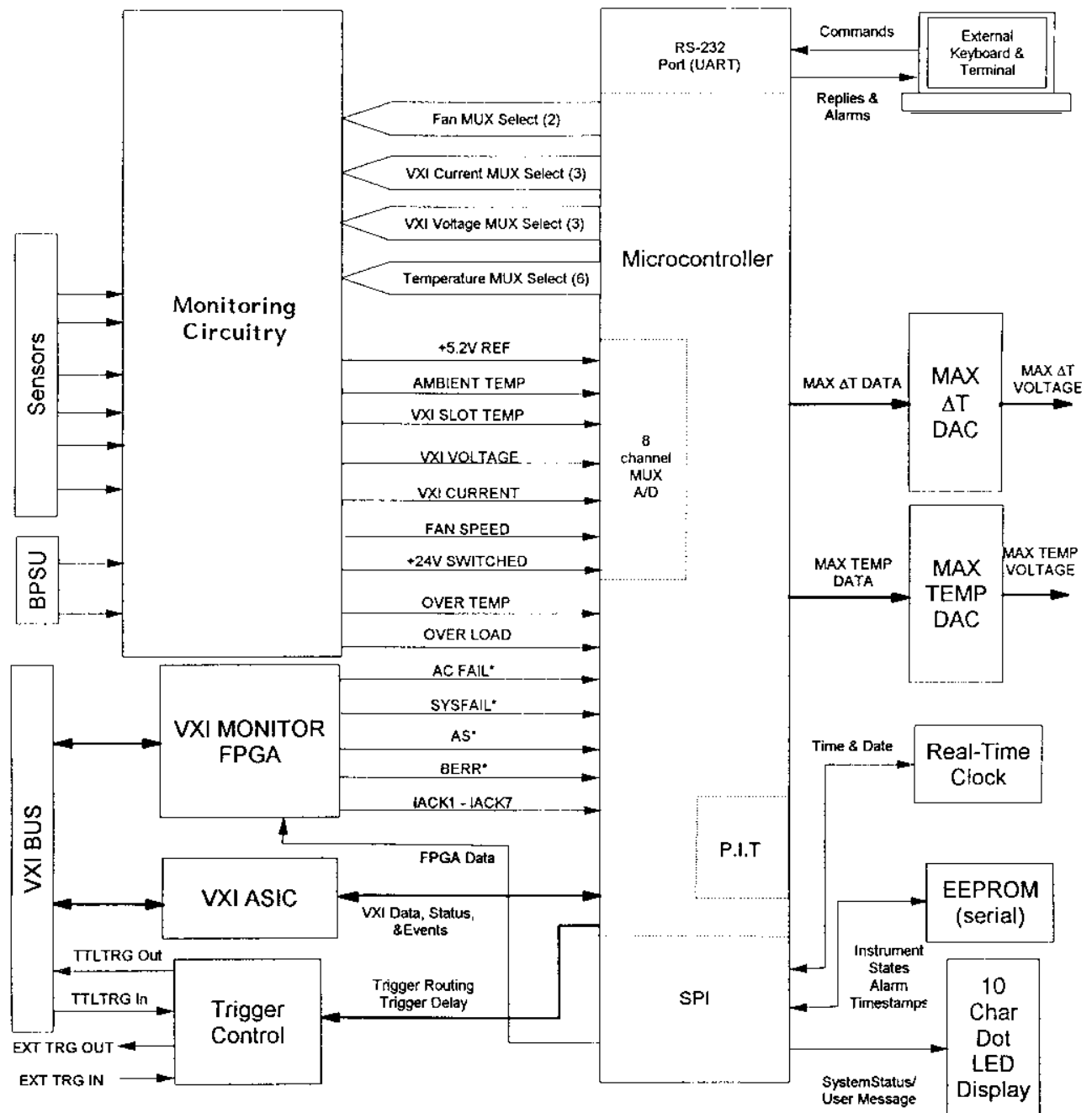

Figure 6-2, Enhanced Monitoring System Module Block Diagram

EMS Module System Interconnection

The Enhanced Monitoring System module plugs directly into the slot 0 location on the rear of the 1261B backplane replacing the SMS monitor.

EMS Module General Capabilities

The **EMS** module general capabilities are listed below. Refer to **Section 4 Using the Enhanced Monitor** for complete information.

Monitoring of the voltages produced by 7 VXI power supplies

- Monitoring of the currents produced by the 7 VXI power supplies
- Monitoring of the ambient temperature and the temperature within the each of the thirteen VXI slots
- Monitoring the speed of each of the three module fans
- Monitoring the VXI Address Strobe (AS*), Bus Error (BERR*), ACFAIL*, SYSFAIL*, and Interrupt Acknowledge (IACK) signals.
- Monitoring the elapsed time since power was turned on (power-on time, both cumulative since shipment and the present total since last power cycle)
- Recording when the last time the VXI Mainframe Filter was serviced, and notifying the user when the service period has elapsed and service is suggested
- Recording when the last time the VXI Mainframe filter was serviced, and notifying the user that filter service is due again.
- Routing a "External Trigger In" signal to one of the TTLTRG<n> lines on the VXI backplane. A programmable delay may be added to the trigger input before the TTLTRG<n> trigger output signal is asserted.
- Routing one of the TTLTRG<n> lines from the VXI backplane to an "External Trigger Out" connector. A programmable delay may be added to the trigger before it is output to the "External Trigger Out" connector.
- Calculates the maximum VXI slot temperature rise

relative to the ambient temperature, and outputs a voltage proportional to the maximum temperature rise at the rear panel monitor connector J414.

- Calculates the maximum VXI slot temperature and outputs a voltage proportional to the maximum slot temperature at the rear panel monitor connector J414.
- Provides an RS-232 interface(J412) over which commands may be received and replies sent by the EMS.

User Limits On EMS Monitored Parameters

Many of the monitored functions provide the capability for the user to program upper and/or lower limit values. When a limit is exceeded, the EMS will generate a VXI interrupt (if enabled to do so) which notifies the user of an alarm condition. Refer to **Chapter 4 Using the Enhanced Monitor** for complete information.

Timestamps On EMS Monitored Events

For many of the monitored functions, a timestamp is saved by the EMS software. This time stamp indicates the time of the most recent occurrence of an alarm condition for that monitored function. The timestamp may be queried by the user via SCPI commands. The timestamp includes both time and date information for the alarm. Refer to **Chapter 4 Using the Enhanced Monitor** for complete information.

EMS Rear Panel Fan Speed Monitor

A TTL pulse train at the speed (RPM) of each fan is output to the EMS rear panel Monitor Connector J414. The fans output two pulses per revolution.

EMS Fan Speed Control

The speed of the module fans is controlled by either the slot with the highest absolute temperature or the highest temperature rise.

If the absolute temperature of any slot exceeds +40°C, the module fans operate at full speed. If the temperature rise of any module slot exceeds 10°C, the module fans operate at full speed.

EMS Fan Speed Switch

Switch S3, mounted on the EMS module rear panel, allows the user to select between **maximum** fan speed or **variable** fan speed.

Chapter 7

MAINTENANCE

What's In This Chapter

This chapter provides procedures for inspecting and cleaning the 1261B, removing and replacing mainframe components, and isolating problems to the module level. Refer to **Chapter 6 Understanding The 1261B** for theory of operation information.

Service Strategy

The service procedures in this manual provide removal and replacement procedures to repair the 1261B to the module level. Module level repairs are accomplished by exchanging faulty modules with known good modules or parts. No component-level repair is provided in this manual.

Service Interval

Clean the power supply filter and mainframe module fan filter at a maximum interval of six months. Depending upon the amount of usage and ambient dust levels in the operating environment, the filters may require more frequent cleaning.

Clean dust from the mainframe exterior (and interior) as needed, based on the operating environment. Periodic cleaning reduces instrument breakdown and increases reliability.

Preparation

The information in this section is designed for use by qualified service personnel. Read the **For Your Safety** at the front of this manual and **Service Strategy** before attempting any procedures in this chapter. Refer to **Chapter 3 Operating The 1261B** for information on the location of controls, indicators, and connectors used with the mainframe.



CAUTION

Many components within the mainframe are susceptible to static discharge damage. Service the mainframe only in a static-free environment. Observe standard handling precautions for static-sensitive devices while servicing the mainframe. Always wear a grounded wrist strap, or equivalent, while servicing the mainframe.

Inspection and Cleaning

The mainframe is inspected mechanically and electrically before shipment. It should be free of marks or scratches and should meet or exceed all electrical specifications. To confirm this, inspect the mainframe for physical damage incurred during transit. Retain the mainframe packaging if reshipment is necessary.

Cleaning procedures consist of exterior and interior cleaning of the mainframe and cleaning fan filters. Refer to your module user documentation for information on cleaning the individual VXibus modules.

CAUTION

Always power off the mainframe and disconnect the power cord before cleaning or servicing the mainframe.

Interior Cleaning

Use a dry, low-velocity stream of air to clean the interior of the mainframe. Use a soft-bristle brush for cleaning around components. If you must use a liquid for minor interior cleaning, use a 75% isopropyl alcohol solution and rinse with deionized water.

Exterior Cleaning

Clean the exterior surfaces of the mainframe with a dry lint-free cloth or a soft-bristle brush. If any dirt remains, wipe with a cloth moistened in a mild soap solution. Remove any soap residue by wiping with a cloth moistened with clear water. Do not use abrasive compounds on any part of the mainframe.

CAUTION

Avoid getting moisture inside the mainframe during exterior cleaning - use just enough moisture to dampen the cloth.

Do not wash the front or rear panel connectors or switches. Cover these components while cleaning the mainframe.

Do not use chemical cleaning agents; they may damage the mainframe. Avoid chemicals that contain benzene, toluene, xylene, acetone, or similar solvents.

Cleaning The Power Supply Filter

The supply filter is easily removed from the rear of the mainframe as shown in Figure 7-1.

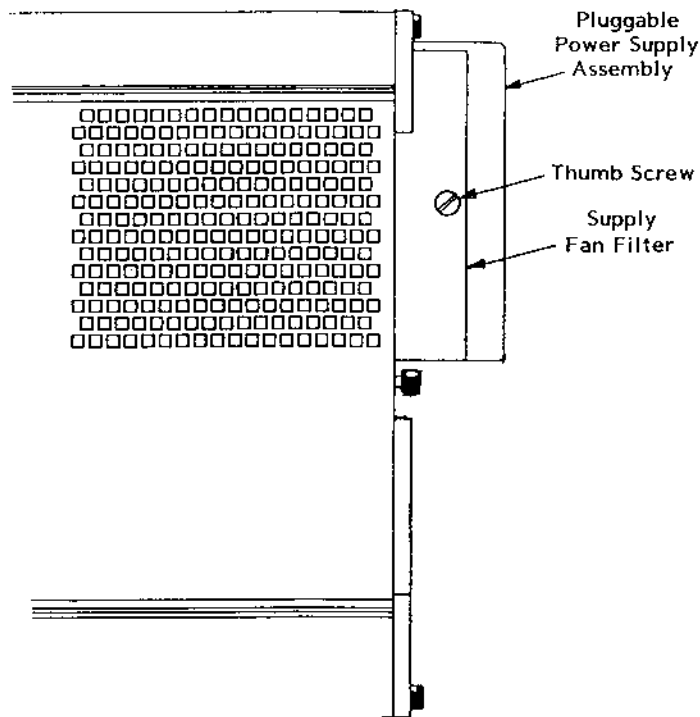

Figure 7-1, Cleaning The Supply Fan Filter

1. Loosen the captive thumb screw retaining the supply fan filter.
2. Remove the supply fan filter towards the rear.
3. Clean the supply fan filter by washing in mild soap solution, vacuuming or blowing air through the filter. Rinse the filter with water and dry before replacing it in the mainframe.

Cleaning The Module Fan Filter

The module fan filter is easily removed from the rear of the chassis as shown in **Figure 7-2**.

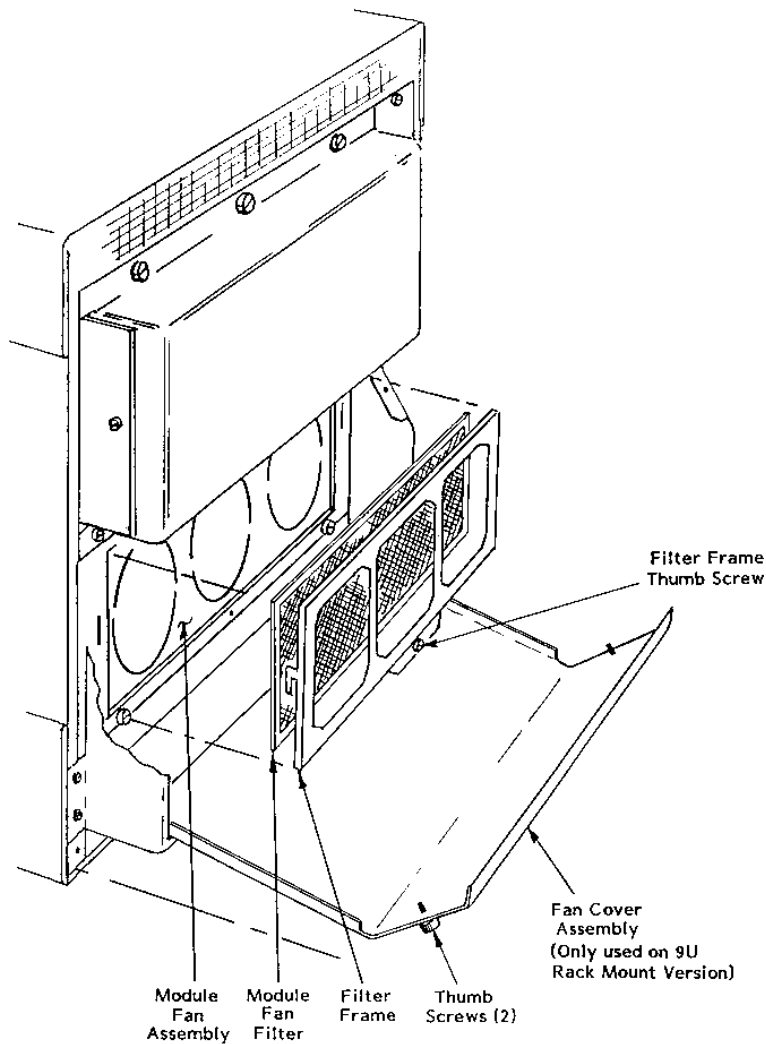

Figure 7-2, Cleaning The Module Fan Filter

1. On rackmount (9U) mainframes only, loosen the two captive thumbscrews on the fan cover assembly and allow it to swing open. It will pivot about its base allowing access to the module fan filter and frame.
2. Loosen the lower center captive thumbscrew on the module fan filter frame. Lift it up and towards the rear to remove the frame and filter from the rear of the module fan assembly.
3. Clean the fan filter by washing, in mild soap solution, vacuuming or blowing air through the filter. Rinse the filter with water and dry before replacing it in the mainframe.
4. To replace, install the filter into the frame.
5. Align the hooks on the back of the filter frame with the slots on the fan assembly. Insert the frame and push down to engage.
6. Tighten the captive thumbscrew to secure the fan filter frame.
7. On rackmount mainframe only, swing the module fan cover upwards and forward, and secure with thumbscrews.

Modular Component Removal and Replacement

The following procedures describe how to remove and replace module-level components of the 1261B Mainframe. Perform these procedures only as necessary as part of installation (e.g. fuse replacement), mainframe service, or repair. Refer to the **Assembly Drawings** in this chapter for an overview of the assembly and disassembly of the mainframe. See **Troubleshooting** for assistance in fault isolation.

CAUTION

Always power off the mainframe and disconnect the power cord before cleaning or servicing the mainframe.

Tools Required

The only tool required to disassemble the 1261B chassis to the module level is a medium flat blade screwdriver. (Exceptions: 9U Fan Assembly removal requires #2 Phillips screwdriver and 7/64 hex keywrench.)

Removal and Replacement of The Module Fan Assembly

The plug-in module fan assembly may be removed and replaced as described in the following steps. Refer to **Figure 7-3** and **7-4**.

1. On rackmount (9U) mainframes only, loosen fan cover thumbscrews, lower cover and disengage from housing. Remove two phillips head screws per side and two socket-head cap (Allen) screws and lockwashers inside rear of cabletray. Pull bottom of housing away and downwards disengaging retaining hooks from rear of module fan assembly. This will expose the fan assembly for removal. Omit this step for benchtop (7U) mainframes.
2. Loosen the lower center captive thumbscrew on the fan filter frame. Lift it up and towards the rear to remove the frame and filter from the rear of the module fan assembly.
3. Loosen the four captive thumbscrews which secure the module fan assembly to the mainframe.
4. Ensure that all four thumbscrews are disengaged from the mainframe. Grasp the module fan assembly by the bottom right and top left floating thumbscrew.
5. Remove the module fan assembly by pulling gently toward the rear of the mainframe while gripping the assembly by the two thumbscrews.
6. To reinstall the module fan assembly, first align the assembly with the rear of the mainframe.
7. Insert the fan assembly by gently pushing it forward into the mainframe making sure the electrical connector is properly mated.
8. Tighten the four thumbscrews securing the module fan assembly.
9. Place filter in the filter frame and align the hooks on the back of the filter frame with the slots on the module fan assembly. Insert the frame and push down to engage.
10. Tighten the captive thumbscrew to secure the fan filter frame.
11. On rackmount mainframe only, engage the hooks on rear of fan cover assembly with the slots in the rear of the fan assembly. Push up to seat and secure with hardware removed in Step 1.

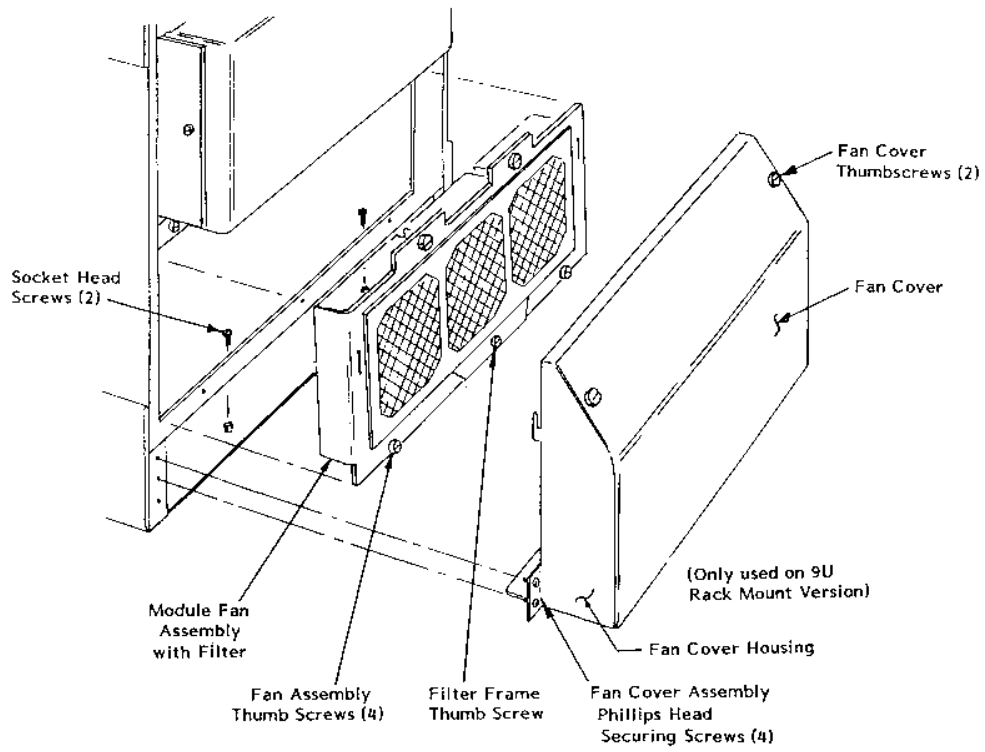

Figure 7-3, Module Fan Assembly Detail

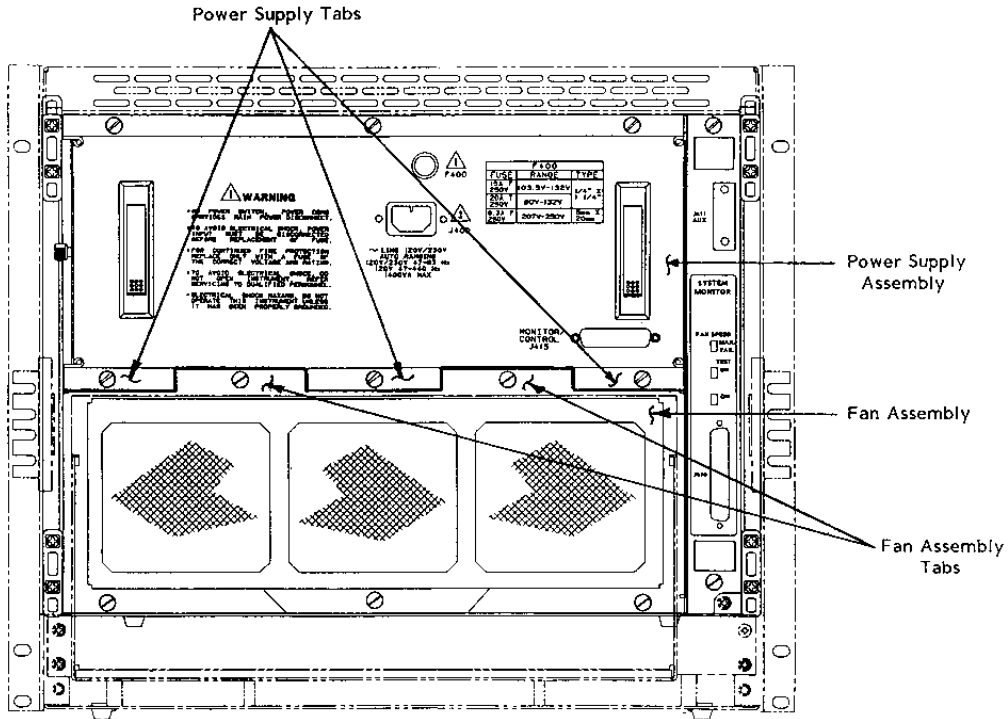

Figure 7-4, Aligning The Module Fan Assembly

Removal and Replacement of The Power Supply Assembly

To remove and install the power supply assembly from the mainframe. Refer to **Figure 7-5** and perform the steps below.

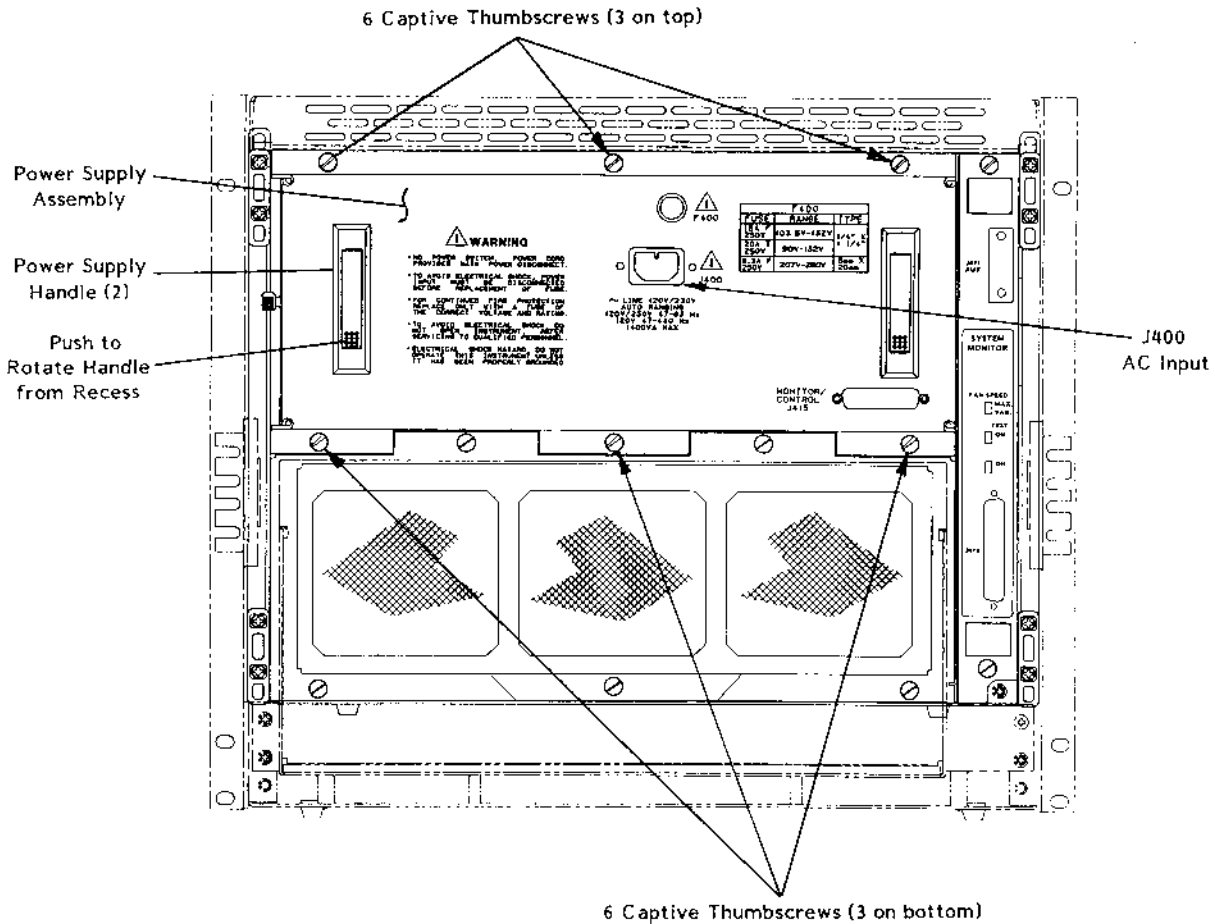

Figure 7-5, Power Supply Rear View

1. Unplug the AC power cord from the rear panel of the 1261B.
2. Loosen the six captive thumbscrews which secure the power supply to the mainframe. See **Figure 7-5** for locations of these six thumbscrews. Ensure that the threads of the six thumbscrews are disengaged from the captive pem nut on the mainframe.
3. Push the base of the recessed handles to rotate and expose the mainframe handles.

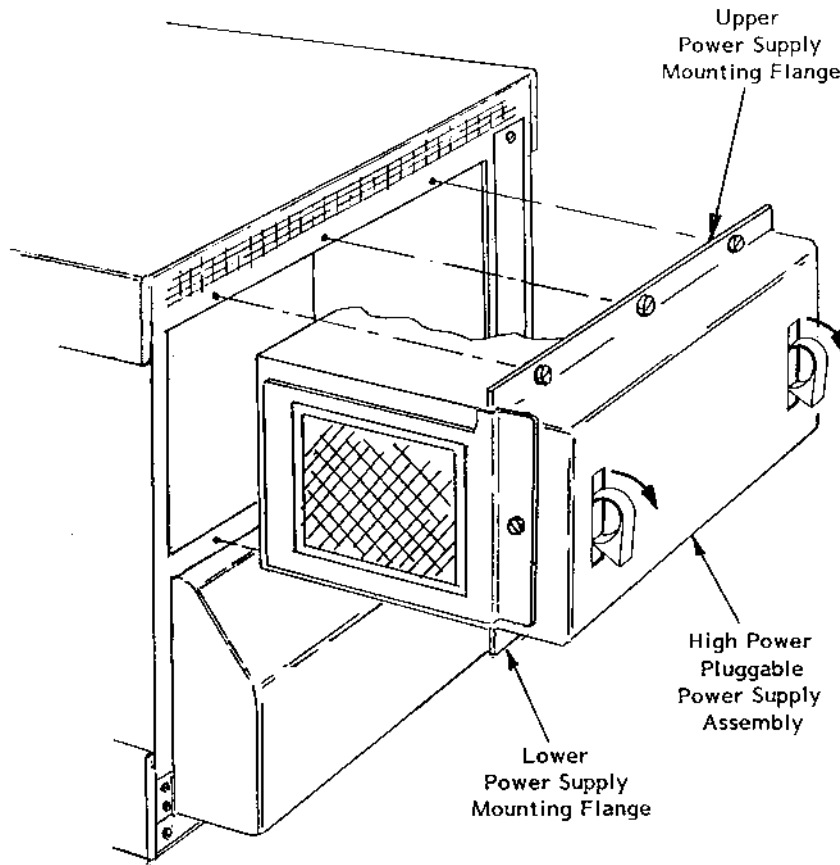

Figure 7-6, Removing The Power Supply

4. Firmly grasp each handle and pull evenly using a slight side to side rocking motion. If the power supply is difficult to remove, recheck to make sure all the thumbscrews are disengaged.
5. To reinstall a power supply into the mainframe, first align the power supply with the cavity at the rear of the mainframe. Note that the silkscreen on the supply rear panel will read correctly when the supply is in the proper orientation. Use the alignment of the threads on the upper fasteners as a visual guide.
6. Gently guide the power supply forward until engagement of the blind-mate connector is felt.
7. Exert pressure by using the palm of hand to assist final engagement.
8. When fully seated tighten the six thumbscrews. Do not over-tighten.

Removal and Replacement of The System Monitor

This procedure applies to the Standard Monitoring System module and the Enhanced Monitoring System (EMS) module. Refer to Figures 7-7 and 7-8 while following the steps below.

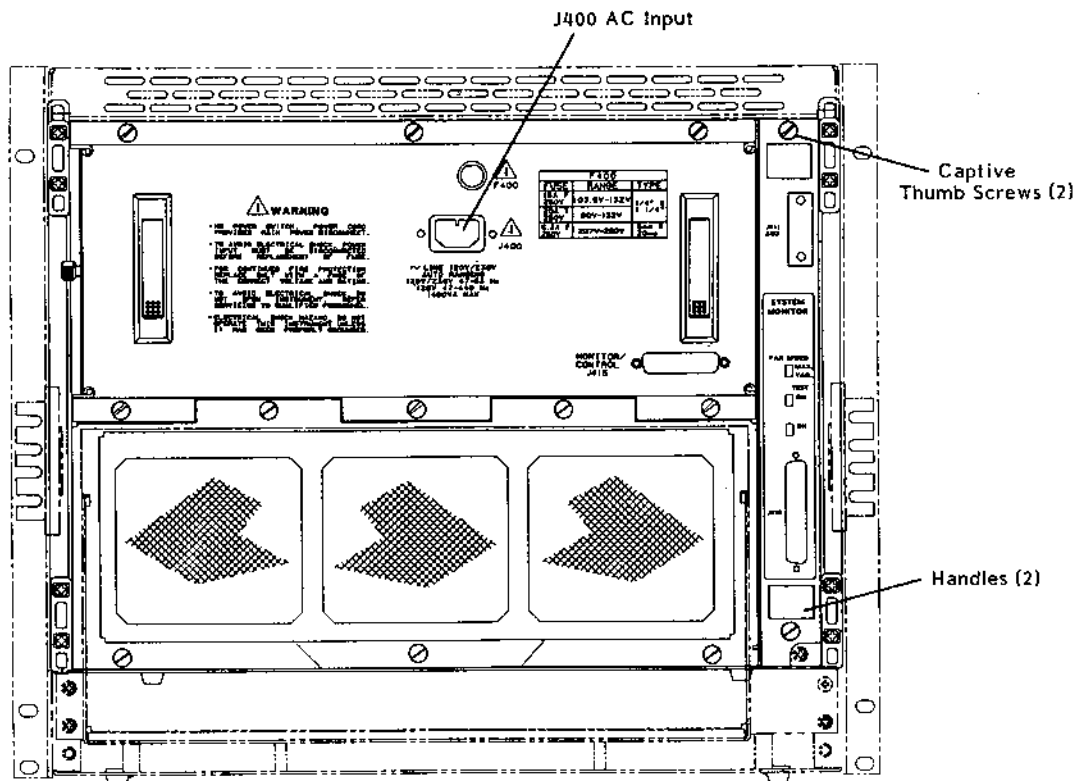

Figure 7-7, Monitor System Module Rear View

WARNING

Ensure that J400 AC Input is disconnected before removing or replacing the System Monitoring (SMS or EMS) module. Possible damage to the module could result.

1. Loosen the two captive thumbscrews which secure the monitoring system to the mainframe.
2. Grasp the module by the top and bottom handles.
3. Carefully pull to the rear to remove the system monitor module.

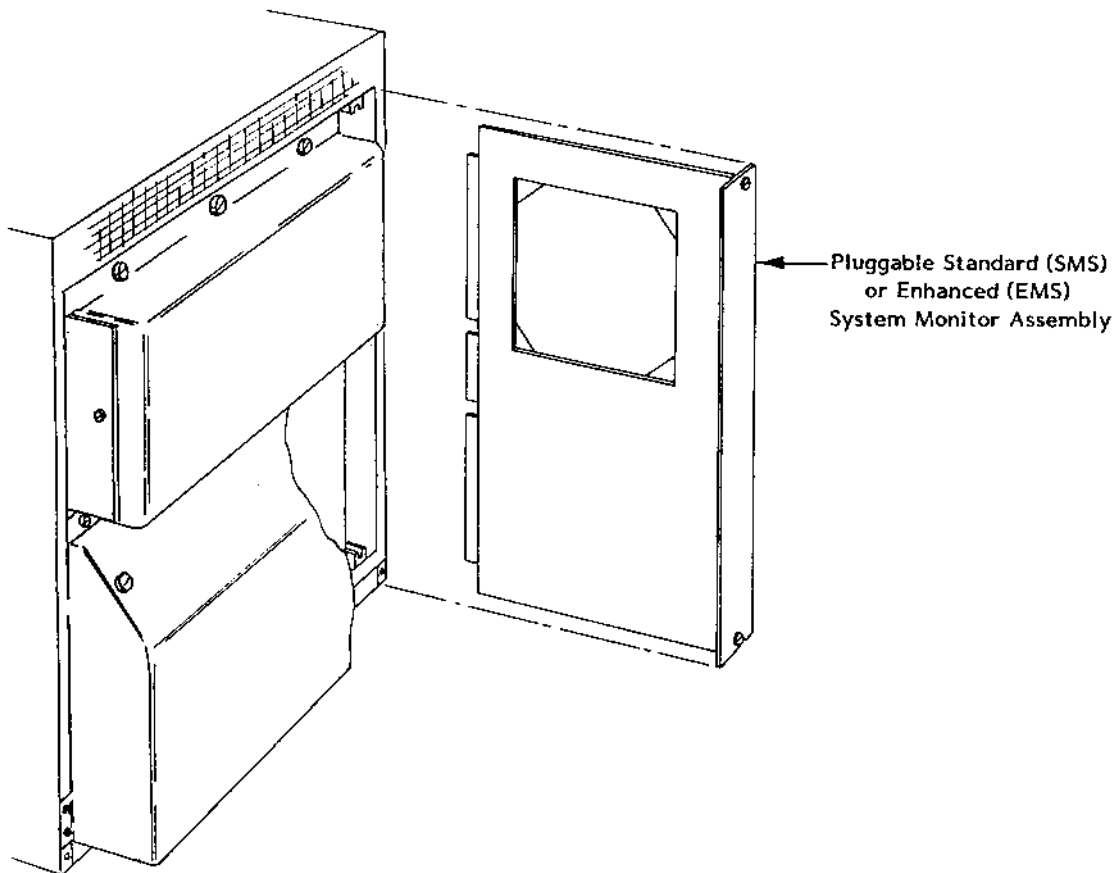

Figure 7-8, Monitoring System Module Removal and Replacement

4. To reinstall the monitoring system module, align in the card guides at rear of the mainframe.
5. Gently insert the module into the mainframe ensuring proper engagement in the card guides.
6. Firmly push the module forward to seat into the backplane connectors.
7. Tighten the two captive thumbscrews securing the module.

Removal and Replacement of The AC Mains Fuse

Complete the steps below while referring to Figure 7-9.

WARNING

To avoid electrical shock, the AC mains power input must be disconnected before replacement of the fuse.

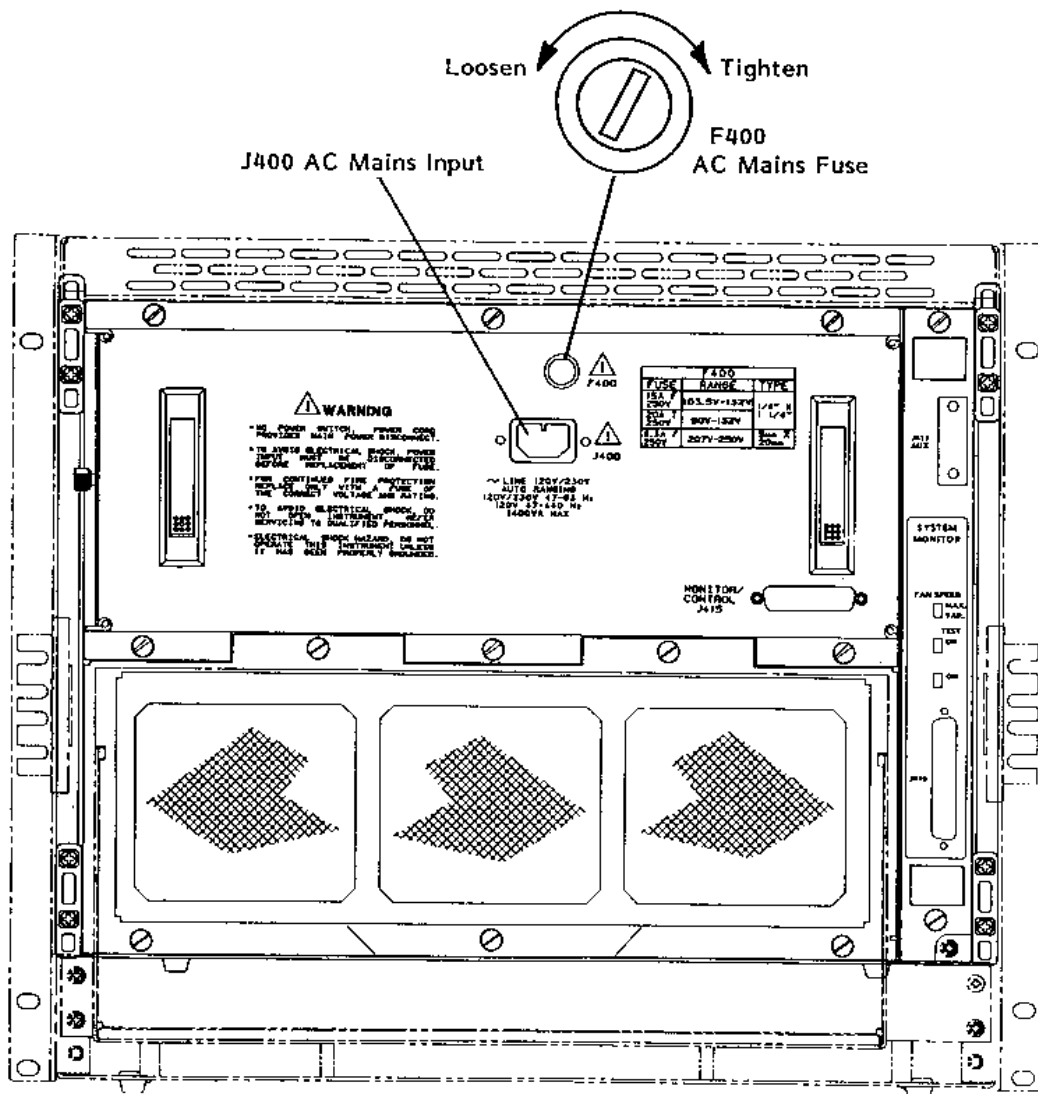

Figure 7-9, Removing and Replacing The AC Mains Fuse

1. Ensure AC mains input (J400) is disconnected.
2. Insert flat blade screwdriver into fuse carrier slot at F400 in power supply rear panel and rotate counter clockwise to remove.
3. To replace fuse, insert the fuse carrier and fuse assembly into fuse housing opening for F400 on power supply.
4. Insert flat blade screwdriver into fuse carrier and rotate clockwise to lock fuse assembly in place.

Removing and Replacing The Card Guides

Complete the steps below while referring to **Figure 7-10** to remove and replace the card guides. The procedure applies to top and bottom card guides.

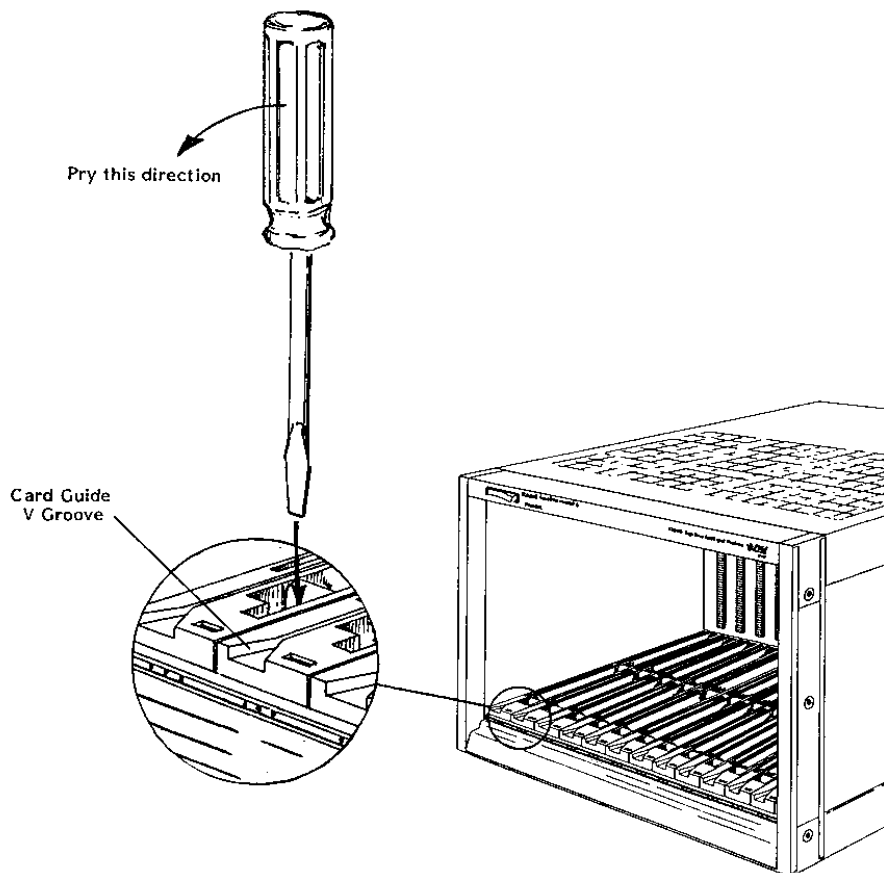

Figure 7-10, Card Guide Removal and Replacement

1. Insert a flat blade screwdriver into the slot in front of the retaining hook.
2. Gently pry the tab of the retaining hook to the rear, and lift the card guide, releasing it at the front.
3. Gently pull the card guide forward releasing it from the center and rear retaining hooks. Bowing the card guide is required to clear the front rail.
4. To replace, align the card guide with the mainframe front ensuring that the "V" groove is at the front.
5. Gently push down and to the rear to engage the hooks at the rear and middle of the card guide. Bowing the card guide is required to clear the front rail.
6. Allow the front retaining hook to rest on the front rail.
7. Insert a flat blade screwdriver into the slot in front of the retaining hook.
8. Gently pry the tab of the retaining hook to the rear, and press down the front of the card guide to snap into position.

Troubleshooting The 1261B

To troubleshoot the 1261B VXIbus mainframe to its component module level use **Table 7-1** and **Understanding the 1261B** in Chapter 6.

"Alarm conditions" referenced in the **PROBLEM** column of **Table 7-1** occur when the monitored system health status function (Voltage, Current, Temperature, or Airflow) is outside of its specified tolerance. For information on health status indicators and tolerance limits refer to **Table A-8** or **A-9** for SMS or EMS equipped mainframe, respectively.

Table 7-1, Troubleshooting

PROBLEM	POSSIBLE CAUSES	WHAT TO DO
<p>“Power” annunciator does not come on</p>	<ul style="list-style-type: none"> • 1261B mainframe not connected to power source. • Power/On/Standby switch not switched on. • Remote inhibit input on rear panel of power supply is active. • Blown AC Mains Fuse. • Power supply protections are active causing the supply to be “shutdown”. • Power supply not fully seated. • Faulty wiring to front panel Power On/Standby Switch 	<ul style="list-style-type: none"> • Make sure that the 1261B is connected to a live electrical outlet. Try operating another piece of equipment from this outlet. • Set the front Power On/Standby switch to the ON position (See “Powering On The Mainframe” in Chapter 3). • Remove the inhibit by opening the remote switch (or deasserting the remote open collector driver). See “Using Remote Power On/Standby Switching” in Chapter 3. • Unplug AC mains power and check the fuse. See “Removing and Replacing the AC Mains Fuse” in Chapter 7. • Refer to “Power Supply Protections” in Chapter 6. • Cycle power to clear fault. If fault persists remove installed VXI modules (cycle power) until fault is cleared. • Verify that the power supply assembly is fully seated and all six thumbscrews are fastened. See “Removing and Replacing the Power Supply” in Chapter 7. • Verify integrity of wiring to Power On/Standby switch. Contact customer service.

PROBLEM	POSSIBLE CAUSES	WHAT TO DO
Voltage alarm condition.	<ul style="list-style-type: none"> • Faulty VXI module installed or voltage fault occurred • VXI supply is out of tolerance 	<ul style="list-style-type: none"> • Cycle power. • If fault persists remove installed VXI modules until fault indication is cleared. • Perform Basic Functional Check procedure from Chapter 3. • For EMS equipped mainframe check VXI supply voltage levels and that alarm limits are valid. (See Chapter 4)
Current alarm condition	<ul style="list-style-type: none"> • VXI supply DC output current exceeds tolerance 	<ul style="list-style-type: none"> • Cycle power • Check current monitors using a DMM at J415. See Chapter 3 Rear Panel Connector Reference. • On EMS equipped mainframe check current draw values and limits from monitor. See Chapter 4.
Temperature alarm condition	<ul style="list-style-type: none"> • Module temperature rise or max ambient limit exceeded <li style="text-align: center;">or • Insufficient module cooling air 	<ul style="list-style-type: none"> • Check ΔT and Tmax outputs at rear panel. • Check for restrictions to airflow at mainframe intake and exhaust. • Check fan TACH outputs at rear panel. • Query EMS to check ambient temperature, slot temperature rise, and fan speed to verify values and limits. Refer to Chapter 4. • Clean mainframe module cooling fan filter.

PROBLEM	POSSIBLE CAUSES	WHAT TO DO
Airflow alarm condition	<ul style="list-style-type: none"><li data-bbox="505 304 854 363">• Fan speed tolerance limit exceeded	<ul style="list-style-type: none"><li data-bbox="886 304 1399 363">• Check fan TACH outputs at rear panel<li data-bbox="886 405 1399 506">• Query EMS to check fan speed values and to verify limits. Refer to Chapter 4.<li data-bbox="886 541 1399 600">• Check for restrictions to airflow at mainframe intake and exhaust.<li data-bbox="886 642 1399 701">• Clean mainframe module cooling fan filter.

Assembly Drawings

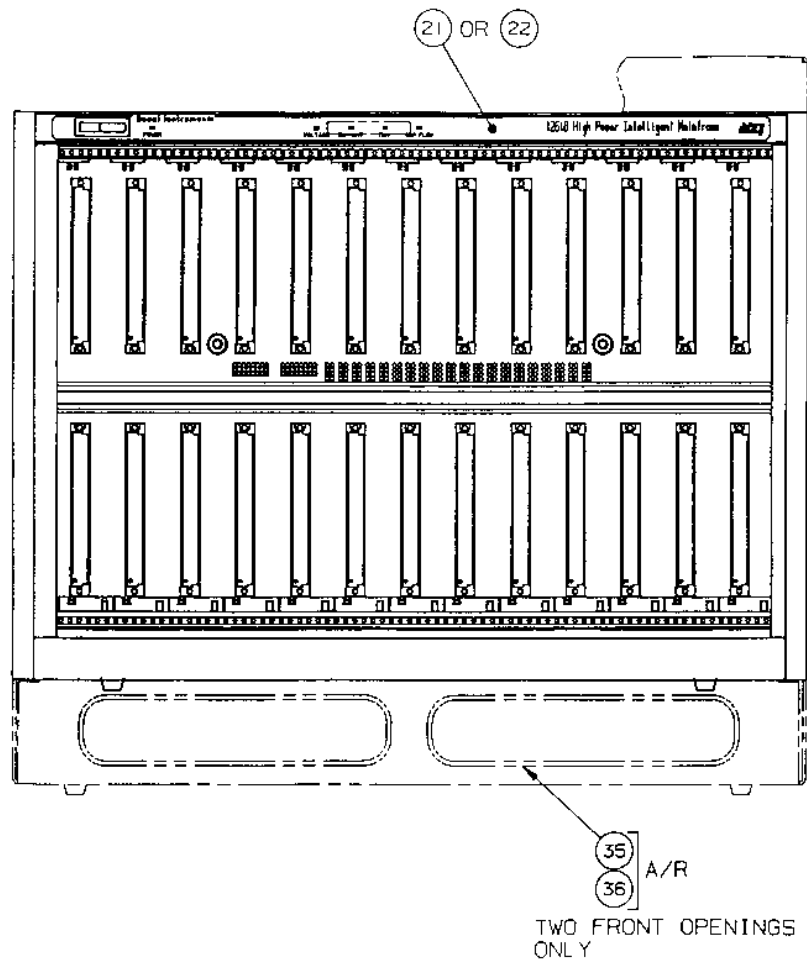
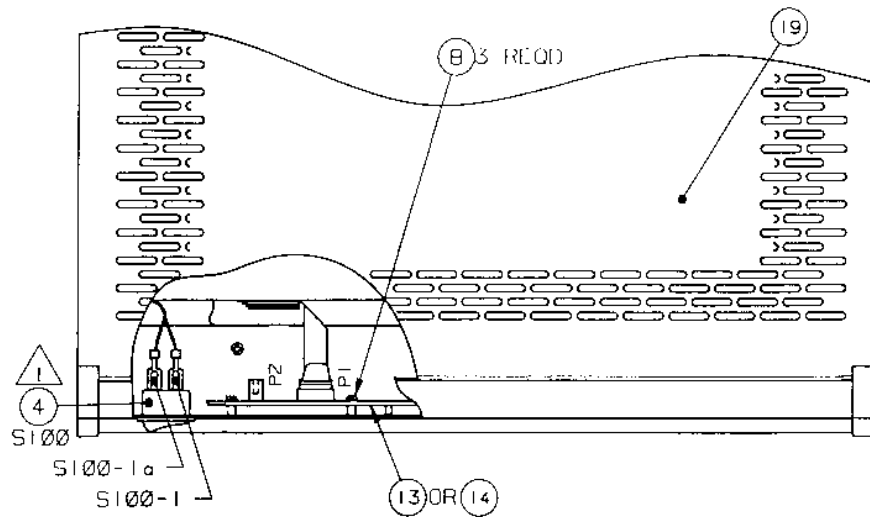

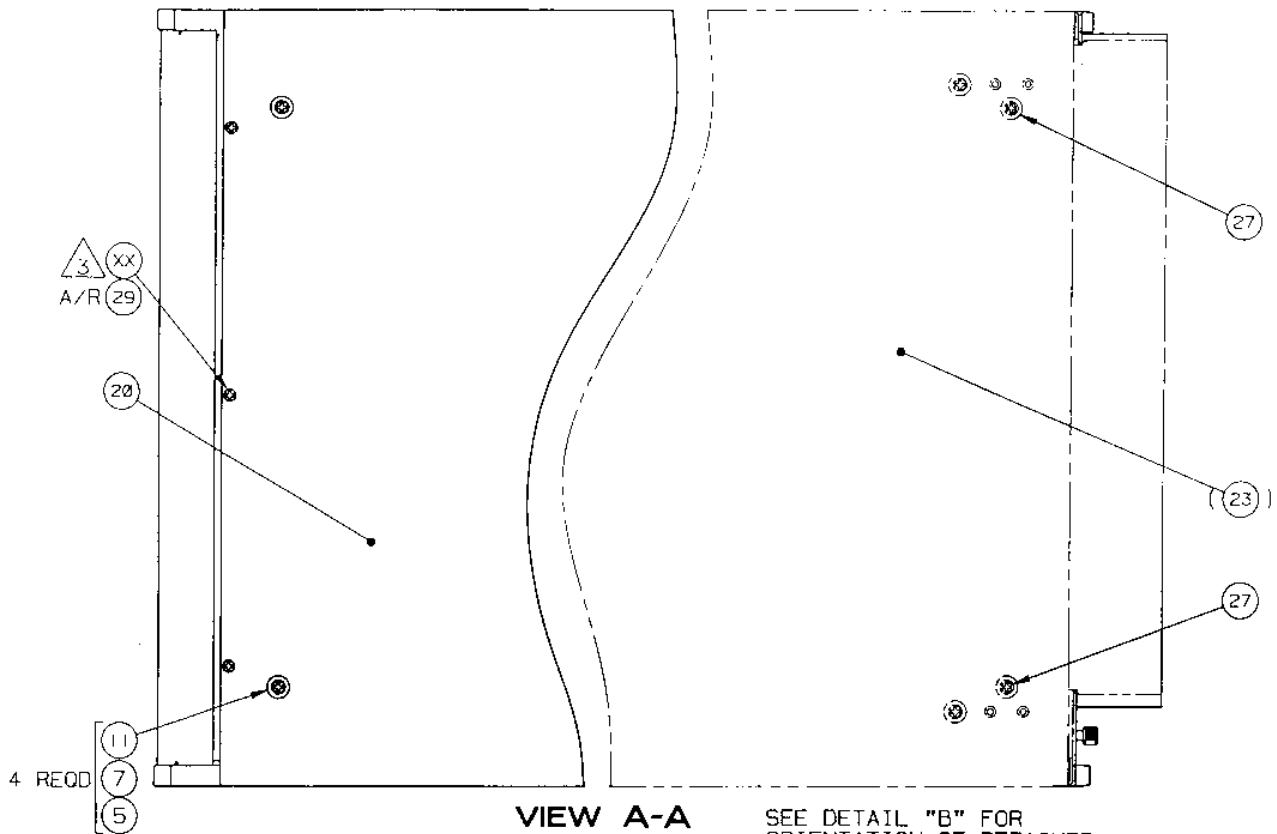

SEE DETAIL "B" FOR ORIENTATION OF RETAINER MOUNTING IN 9U CHASSIS

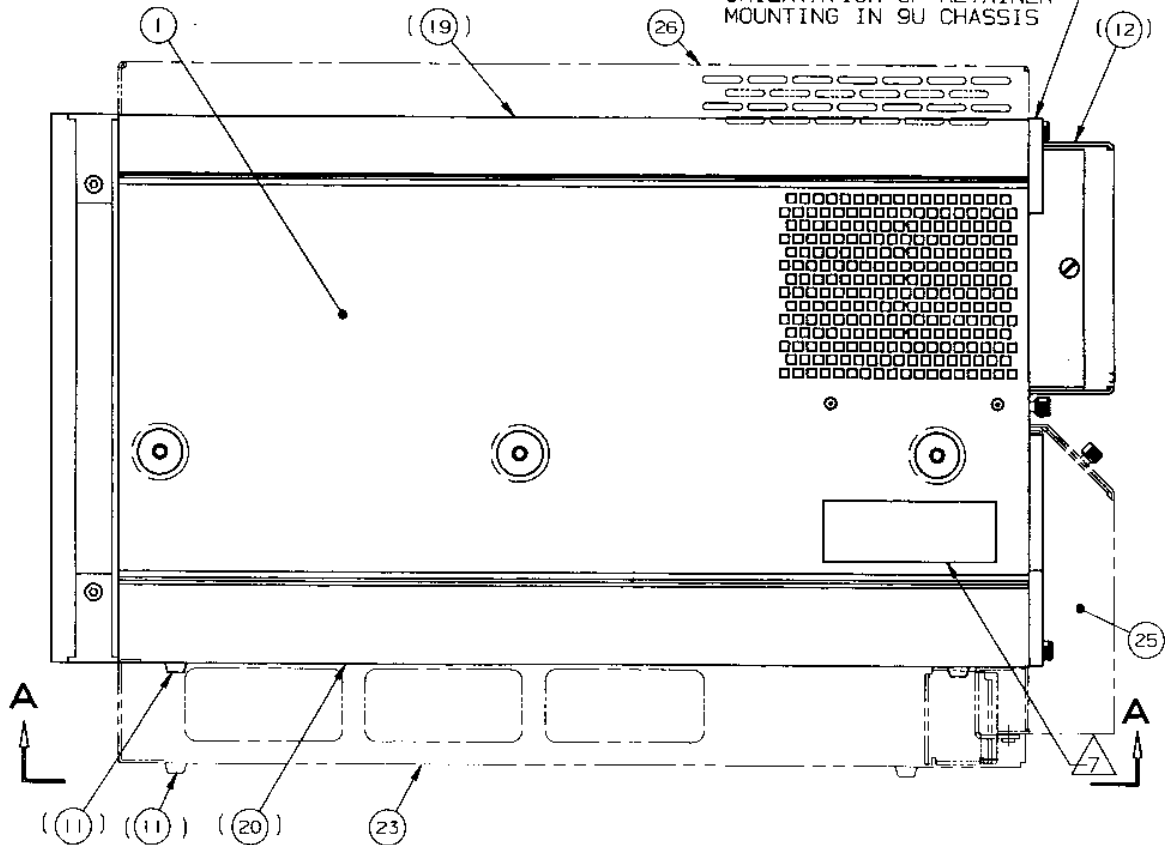

NOTES

- △ CONNECTION FROM 405095-J54 TO S100 ITEM (4) AS FOLLOWS:
 - 405095-J54-3 TO S100-1
 - 405095-J54-5 TO S100-1a
- △ 3 FOR -OX1XX MODELS USE ITEM (28), QTY. 3.
 FOR -OX2XX MODELS USE ITEM (27), QTY. 3.
- △ 6 BEFORE INSTALLATION OF ITEM (15) OR (16) SET JUMPER J14 ON ITEM (15) OR (16) ON COMPONENT SIDE AS FOLLOWS:
 TO 2-3 POSITION FOR -OX2XX MODELS (9U)
 TO 1-2 POSITION FOR -OX1XX MODELS (7U)
- △ 7 PRINT BAR CODE IDENTIFICATION LABEL WITH PERTINENT DATA USING BRADYCODE BAR CODE SOFTWARE AND AFFIX APPROXIMATELY WHERE SHOWN. (SOFTWARE PART NO. 800522).

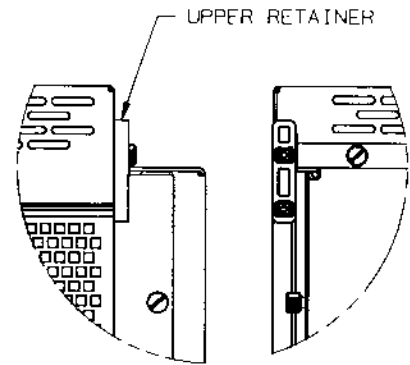

DETAIL B

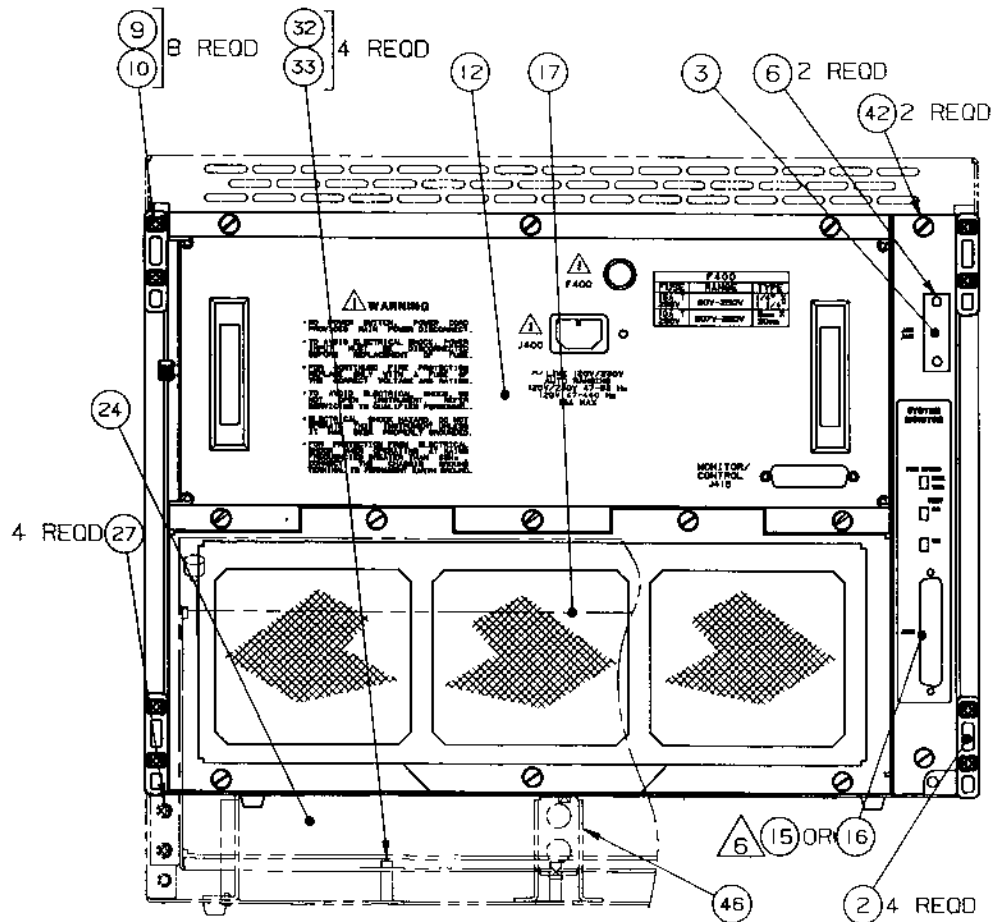

407374-01111/01112 - 1261B 7U CHASSIS WITH MONITOR
 407374-01211/01212 - 1261B 9U CHASSIS WITH MONITOR

Rev. L

REF DESIG	RACAL INST P/N	DESCRIPTION	FSC	MANUFACTURER'S P/N
S100	602235	SWITCH, ROCKER, SNAP-IN	21793	602235
{1}1	407378	ENCLOSURE ASSY, 1261B	21793	407378
{2}4	456341	FOOT, REAR	21793	456341
{3}1	456379	PANEL, CONNECTOR, FILLER	21793	456379
{5}5	610873	WASHER, FLAT, #6 SS, MS NA5620-C6L	-	-
{6}2	611327	RIVET, SNAP, SR, BLACK (.118-.157)	06915	SR-3055BK
{7}4	615059	SCREW, PPH, 6-32 X .375	-	-
{8}3	616251	SCREW, PPH, SEMS ASSY, 4-40X.250	78189	SEMS W/SQ CONE WA.
{9}8	617103	WASHER, FLAT, LIGHT, #6	-	-
{10}8	618112	SCREW, PPH, 6-20 X .500, TAPPING, TYPE B	-	-
{11}4	921054	RECESSED BUMPER	6T698	101-BN-1026
{12}1	407377	POWER SUPPLY ASSY, 1261B	21793	407377
SM {13}1	405091-001	PCB ASSY, DISPLAY, STANDARD	21793	405091-001
EM {14}1	405091-002	PCB ASSY, DISPLAY	21793	405091-002
SM {15}1	405092	PCB ASSY, SYSTEM MONITOR	21793	405092
EM {16}1	405094	PCB ASSY, ENHANCED MONITOR	21793	405094
{17}1	407375	FAN ASSY, 1261B	21793	407375
7U {19}1	456352	COVER, TOP	21793	456352
7U {20}1	456353	COVER, BOTTOM	21793	456353
SM {21}1	456376-001	OVERLAY, FRONT PANEL, LED	21793	456376-001
EM {22}1	456376-002	OVERLAY, FRONT PANEL, DISPLAY	21793	456376-002
{23}1	456382	CABLETRAY, STANDARD W/9U CHASSIS	21793	456382
{24}1	456383	COVER, REAR	21793	456383
9U {25}1	456384	BRACKET, REAR COVER	21793	456384
{26}1	456386	ENCLOSURE, TOP EXTENSION	21793	456386
{27}9	616256	SCREW, PPH, SEMS ASSY, 6-32X.375	78189	SEMS W/SQ CONE WA.
7U {28}3	615558	SCREW, PFH, 100 DEG., CSK, 6-32 X .375	-	-
7U {29}A/R	920962	LOCTITE, 242, MED STR.	05972	272
{30}1	602262	CORD, POWER, 15A	MEGAE	17005-14M
{31}1	980766	INSTRUCTION MANUAL	21793	980766
9U {32}4	615718	SCREW, SLOTTED HEX, 6-32 x .312	-	-
9U {33}4	617128	WASHER, LOCK, #6, LIGHT SERIES	-	-
{34}6	456271	COVER, CARD GUIDE	21793	456271
9U {35}A/R	610388	GROMMET, CATERPILLAR, .040 THICK	03296	G51H-A
9U {36}A/R	921452	LOCTITE, PRISM 411, CLR	05972	PRISM411
{46}1	456583	STIFFENER, CENTER, CABLE TRAY, 9U CH	21793	456583

SM = SYSTEM MONITOR
 EM = ENHANCED MONITOR

7U = 7U MAINFRAME
 9U = 9U MAINFRAME
 OTHER PARTS USED ON BOTH
 7U AND 9U MAINFRAMES.

FSC	SUPPLIER
03296	NYLON MOULDING TEMPLE CITY, CA
05972	LOCTITE CORP. HARTFORD, CT
06915	RICHCO PLASTIC CO. CHICAGO, IL
21793	RACAL INSTRUMENTS INC. IRVINE, CA
6T698	PLASTIGLIDE MFG. CORP. HAWTHORNE, CA
78189	ILLINOIS TOOL WORKS, INC. (SHAKEPROOF DIV.) ELGIN, IL
MEGAE	MEGA ELECTRONICS NEW BRUNSWICK, NJ

Chapter 8

PRODUCT SUPPORT

Product Support

Racal Instruments has a complete Service and Parts Department. If you need technical assistance or should it be necessary to return your product for repair or calibration, call 1-800-722-3262. If parts are required to repair the product at your facility, call 1-949-859-8999 and ask for the Parts Department.

When sending your instrument in for repair, complete the form in the back of this manual.

For worldwide support and the office closes to your facility, refer to the Support Offices section on the following page.

Reshipment Instructions

Use the original packing material when returning the 1261B to Racal Instruments for calibration or servicing. The original shipping crate and associated packaging material will provide the necessary protection for safe reshipment.

If the original packing material is unavailable, contact Racal Instruments Customer Service for information.

Support Offices

RACAL INSTRUMENTS

United States

(Corporate Headquarters and Service Center)
4 Goodyear Street, Irvine, CA 92618
Tel: (800) 722-2528, (949) 859-8999; Fax: (949) 859-7139

5730 Northwest Parkway Suite 700, San Antonio, TX 78249
Tel: (210) 699-6799; Fax: (210) 699-8857

Europe

(European Headquarters and Service Center)
18 Avenue Dutartre, 78150 LeChesnay, France
Tel: +33 (0)1 39 23 22 22; Fax: +33 (0)1 39 23 22 25

29-31 Cobham Road, Wimborne, Dorset BH21 7PF, United Kingdom
Tel: +44 (0) 1202 872800; Fax: +44 (0) 1202 870810

Via Milazzo 25, 20092 Cinisello B, Milan, Italy
Tel: +39 (0)2 6123 901; Fax: +39 (0)2 6129 3606

Technologie Park, Friedrich Ebert Strasse, 51429 Bergisch Gladbach,
Germany
Tel: +49 (0) 2204 844200; Fax: +49 (0) 2204 844219

REPAIR AND CALIBRATION REQUEST FORM

To allow us to better understand your repair requests, we suggest you use the following outline when calling and include a copy with your instrument to be sent to the Racal Instruments Repair Facility.

Model _____ Serial No. _____ Date _____

Company Name _____ Purchase Order # _____

Billing Address _____
City _____

State/Province _____ Zip/Postal Code _____ Country _____

Shipping Address _____
City _____

State/Province _____ Zip/Postal Code _____ Country _____

Technical Contact _____ Phone Number () _____

Purchasing Contact _____ Phone Number () _____

1. Describe, in detail, the problem and symptoms you are having. Please include all set up details, such as input/output levels, frequencies, waveform details, etc.

2. If problem is occurring when unit is in remote, please list the program strings used and the controller type.

3. Please give any additional information you feel would be beneficial in facilitating a faster repair time (i.e., modifications, etc.)

4. Is calibration data required? Yes No (please circle one)

Call before shipping Ship instruments to nearest support office
Note: We do not accept listed on back.
"collect" shipments.

Appendix A

SPECIFICATION

Specifications

This chapter contains the complete specifications for the 1261B Mainframe.

Table A-1, AC Input Specifications

Characteristic	Description
Input Voltage Range	90 V _{RMS} to 250 V _{RMS}
Input Frequency Range	45 Hz to 440 Hz, 120 V operation 45 Hz to 66 Hz, 230 V operation
Power Consumption	1440 W line power maximum
Fuse Rating 90 V - 250 V Operation 207 V - 250 V Operation	0.25 in x 1.25 in, Slow Blow, 15 A, 250 V 5 mm x 20 mm, Slow Blow, 10 A, 250 V
Inrush Current	70 A maximum, cold start or after 1 minute cool down
Input current	15 A maximum at 90 V _{RMS} 8 A maximum at 207 V _{RMS}
Power Disconnect	Front Panel Power On/Standby Switch: Rear panel connection allows for remote inhibit operation. Power cord provides main power disconnect. The Power On/Standby switch must be in Power On position prior to use of remote inhibit.
Protections	Input Current Limit (15 A)
Power Factor Correction	Over entire input voltage range, 45 Hz to 66 Hz

Characteristic	Description		
Maximum Load Ripple/Noise	Voltage	Ripple/Noise	
	+24 V	150 mV _{pp}	
	+12 V	50 mV _{pp}	
	+5 V	50 mV _{pp}	
	-2 V	50 mV _{pp}	
	-5.2 V	50 mV _{pp}	
	-12 V	50 mV _{pp}	
	-24 V	150 mV _{pp}	
Maximum Induced Ripple/Noise	Voltage	Ripple/Noise	
	+24 V	150 mV _{pp}	
	+12 V	50 mV _{pp}	
	+5 V	50 mV _{pp}	
	-2 V	50 mV _{pp}	
	-5.2 V	50 mV _{pp}	
	-12 V	50 mV _{pp}	
	-24 V	150 mV _{pp}	
Auxiliary DC Outputs (Fused-Self Healing)	Voltage	Current	
	+5 V	1 Amp	
	+12 V	1 Amp	
	+24 V	1 Amp	
Protections	Over voltage protection Over temperature protection Over current protection		
VXI Supply Rear Panel DC Voltage Monitors (J415 Connector)	Voltage	Tolerance, ΔV	
	+24 V	+1.2V, -720 mV	
	+12 V	+600 mV, -360mV	
	+5V	+250 mV, -125 mV	
	-2V	-100 mV, +100 mV	
	-5.2 V	-260 mV, +156 mV	
	-12 V	-600 mV, +360 mV	
	-24 V	-1.2 V, +720 mV	
VXI Supply Rear Panel DC Current Monitors (J415 Connector)		No Load	Full Load
	Voltage	Value	Value
	+24 V	0 V	5 V
	+12 V	0 V	5 V
	+5 V	0 V	5 V
	-2 V	0 V	5 V
	-5.2 V	0 V	5 V
	-12 V	0 V	5 V
	-24 V	0 V	5 V
	7% Accuracy at full load value (5 V), typical		

Table A-3, Cooling

Characteristic	Description
Per Slot Cooling Capacity	Typically 80 W per slot @ 3.5 mm H ₂ O with airflow directors. Figure A-1 shows the worst slot cooling curve of the mainframe. Tested per VXI-8 Rev 2.0
Cooling System	Forced air circulation (positive pressurization).
Fan Speed Control with EMS or SMS	A rear panel switch chooses between full speed and variable speed. On the chassis with EMS, the slot exhaust air temperature and ambient air temperature are monitored to maintain a constant temperature rise across the installed modules.
Fan Speed Control without EMS or SMS	A rear switch on the fan assembly chooses between full speed and low speed. On the chassis without EMS or SMS, the chassis runs quieter when operated outside the rack.
Slot Airflow Direction	P2 to P1, bottom of module to the top of module
Mainframe Intake, Bench Top	Bottom rear of mainframe
Mainframe Exhaust, Bench Top	Top of mainframe.
Mainframe Intake, Rack Mount Model	Bottom sides of mainframe, consistent with industry rack mount cooling practice
Mainframe Exhaust, Rack Mount Model	Rear of mainframe, top rear of mainframe, consistent with industry rack mount cooling practice.
Filter Access (Power Supply and Module Fans)	Filter accessible from rear of the mainframe

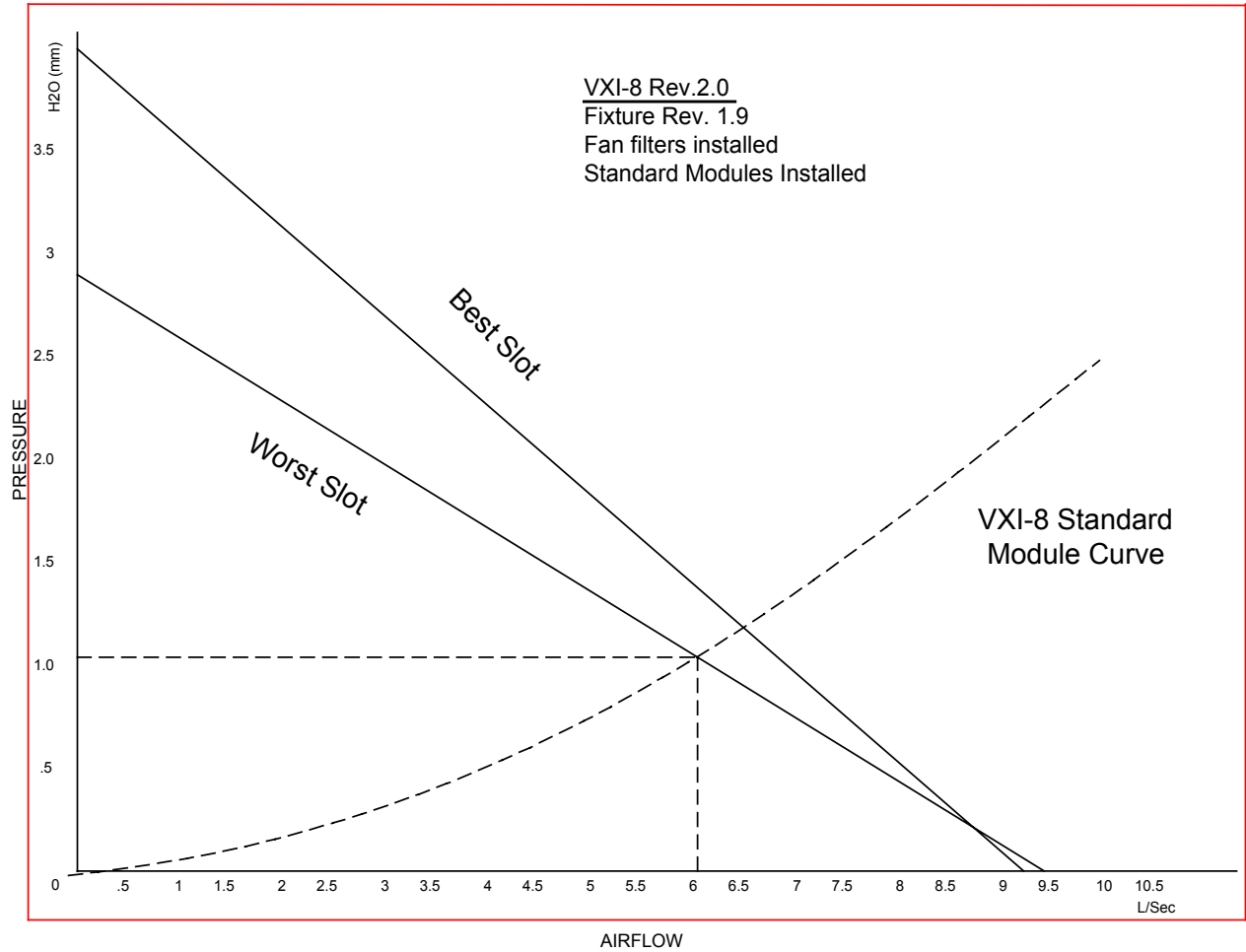

Figure A-1, Mainframe Worst Case Slot Cooling Curve

Table A-4, Safety

Characteristic	Description
Safety Characteristics	UL3111-1, IEC 1010-1, and CAN/CSA-22.2 No. 1010.1
IEC Characteristics	Installation Category II Pollution Degree 2 Safety Class 1

Table A-5 Environmental

Characteristic	Description																
Classification	MIL-T-28800E Type III, Class 5, Style E or F																
Temperature Operating Non-operating	Meets the limits stated in MIL-T-28800E for Type III, Class 5 0°C to 55°C -40°C to 71°C																
Relative Humidity Operating Non-operating	Up to 95% at up to 30°C and up to 45% at up to 55°C Up to 95% at up to 55°C																
Altitude Operating Non-operating	15,000 ft. (4570m) 40,000 ft. (12,190 m)																
Random Vibration Operating Non-operating	Three axis, 30 minutes total, 10 minutes per axis 0.27 g _{RMS} total from 5 Hz to 500 Hz 2.28 g _{RMS} total from 5 Hz to 500 Hz																
Functional Shock Operating	Half sine, 30 g, 11 ms duration. Meets functional shock requirements of MIL-T-28800E, Type III, Class 5 (Operating and Non-Operating)																
User Bench Handling (Operating)	Each edge lifted four inches and allowed to free fall onto a solid wooden bench surface.																
Electromagnetic Compatibility (EMC) Emissions Enclosure AC Mains	Emissions shall be within the limits specified by the following requirements: EN 55011 and EN 55022 Class B FCC Part 15 Class B limits for radiated emissions EN 60555-2 AC power harmonic emissions EN 55011 Class B, FCC Part 15 Class B limits for conducted emissions																
Immunity, Enclosure, Radio Frequency Electromagnetic Field	No mainframe failures when the mainframe is subjected to a 3 V/m electromagnetic field over the frequency range of 27 MHz to 500 MHz.																
Immunity, Enclosure, Electrostatic Discharge (ESD)	Up to 8 kV with no change to control settings or impairment of normal operation.																
Immunity, Fast Transients, Common Mode	<table border="1"> <thead> <tr> <th>Port</th> <th>Peak Voltage</th> <th>Tr/Th</th> <th>Rep Frequency</th> </tr> </thead> <tbody> <tr> <td>Signal&Control</td> <td>0.5 kV</td> <td>5/50 ns</td> <td>5 kHz</td> </tr> <tr> <td>DC Power</td> <td>0.5 kV</td> <td>5/50 ns</td> <td>5 kHz</td> </tr> <tr> <td>AC Power</td> <td>1.0 kV</td> <td>5/50 ns</td> <td>5 kHz</td> </tr> </tbody> </table>	Port	Peak Voltage	Tr/Th	Rep Frequency	Signal&Control	0.5 kV	5/50 ns	5 kHz	DC Power	0.5 kV	5/50 ns	5 kHz	AC Power	1.0 kV	5/50 ns	5 kHz
Port	Peak Voltage	Tr/Th	Rep Frequency														
Signal&Control	0.5 kV	5/50 ns	5 kHz														
DC Power	0.5 kV	5/50 ns	5 kHz														
AC Power	1.0 kV	5/50 ns	5 kHz														
MTBF	41,196 Hours																
MTTR – Power Supply, Fans, Filters, and EMS or SMS module	< 5 minutes																

Table A-6, Backplane

Characteristic	Description
Bus Grant/Interrupt Acknowledge	Solid state, auto-configuring (jumper less)
VXIbus CLK10 Distribution	Full differential

Table A-7, Mechanical

Characteristic	Description
Overall Dimensions 7U Standard Mainframe Height Width Depth	12.22 in (31.0 cm) 17.38 in (44.1 cm) 23.68 in (60.1 cm)
9U Mainframe with Rack Mount Height Width Depth	15.72 in (39.9 cm) 19.00 in (48.3 cm) with rack ears 23.68 in (60.1 cm) to 28.38 in (72.1 cm) in 0.625 inch (1.58 cm) increments, user selectable Standard cable tray used in 9U mainframe provides 16.12 (40.9) x .62 (1.6cm) cable exit area from rear of mainframe. Tray height = 2.25" (5.4 cm)
1U Cable Tray, Option 21 (9U mainframe) Height of the cable tray Width Depth Height including the Chassis	See Figure A-4 for overall mainframe dimensions 3.9 in (9.36 cm) 17.25 in (43.8 cm) 20.12 in (51.1 cm) 17.47 in (44.35 cm)
2U Cable Tray, Option 22 (9U mainframe) Height of the cable tray Width Depth Height including the Chassis	See Figure A-4 for overall mainframe dimensions 5.6 in (13.44 cm) 17.25 in (43.8 cm) 20.12 in (51.1 cm) 19.22 in (48.79)
Weight Bench Top Rack Mount	46 lbs (20.7 kg) with no modules installed 52 lbs (23.7 kb) with no modules installed

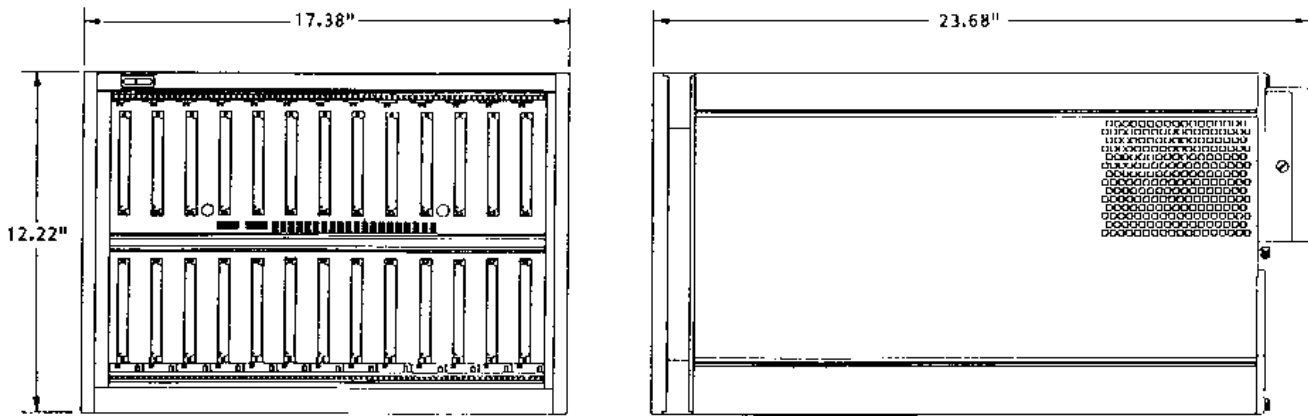

Figure A-2, Front View and Side View of Bench Top (7U) 1261B Mainframe

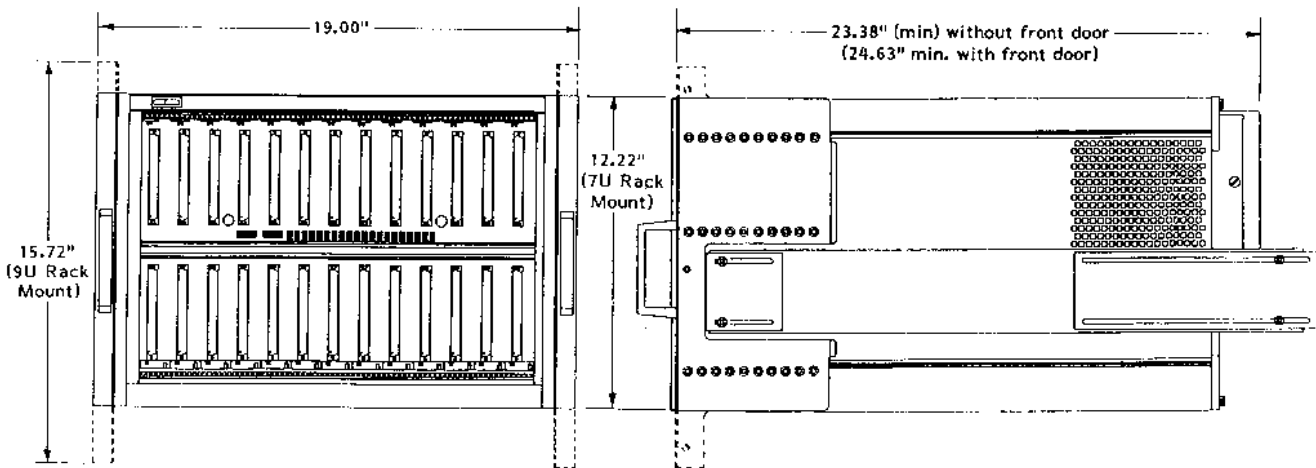

Figure A-3, Front View and Side View of 1261B Bench Top Model With 7U and 9U Rack Mount Ears

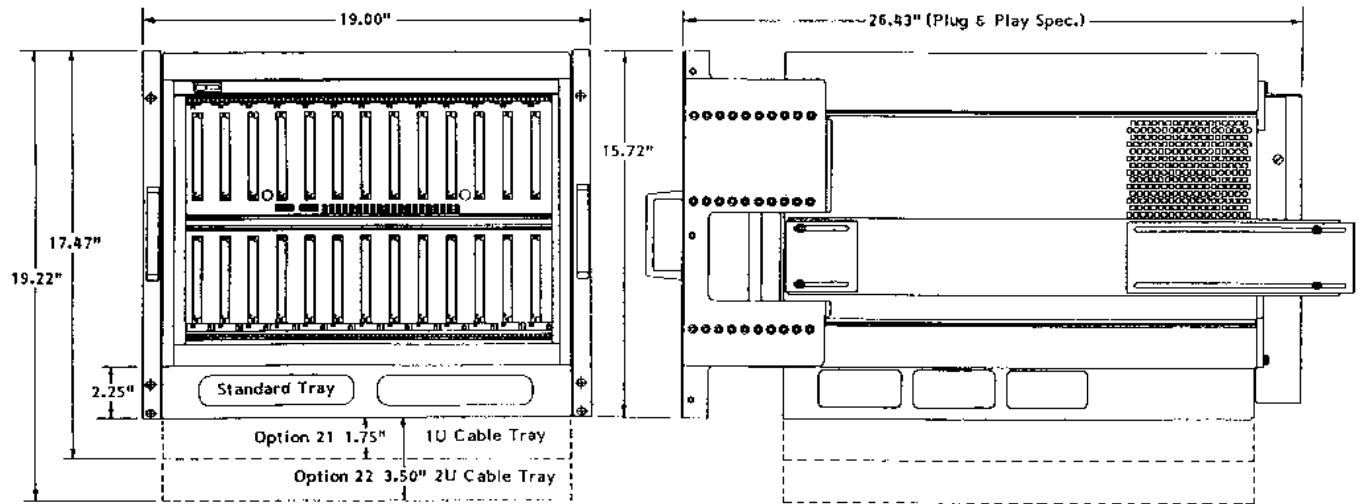

Figure A-4, Front View and Side View of 1261B Rack Mount Model With Rack Mount and Cable Tray Options

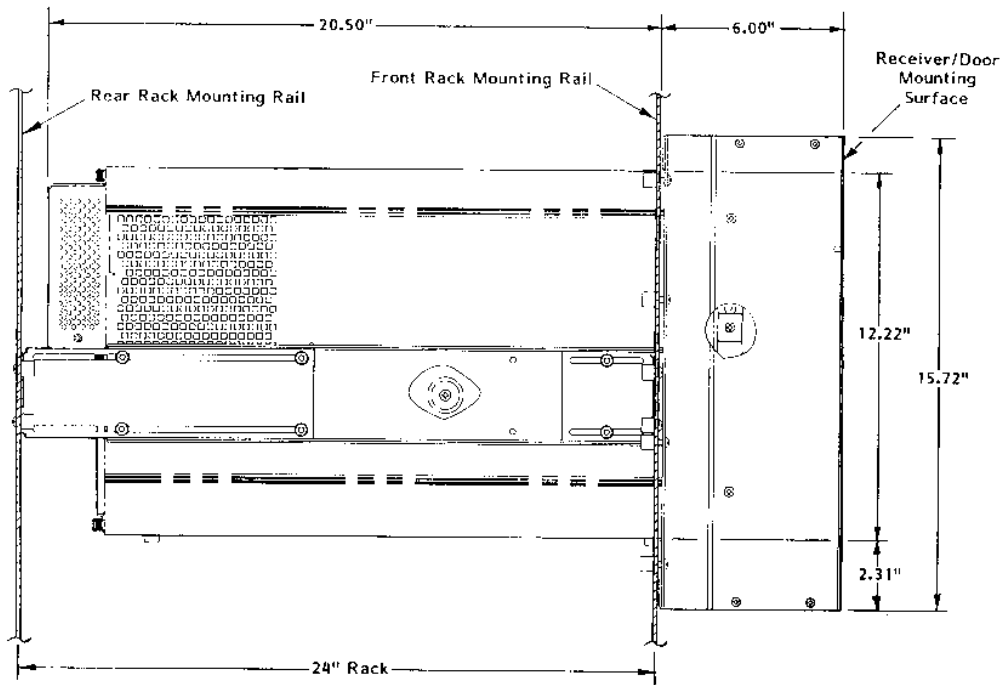

Figure A-5, Side View of 1261B 7U Mainframe With Option 54-1 Installed

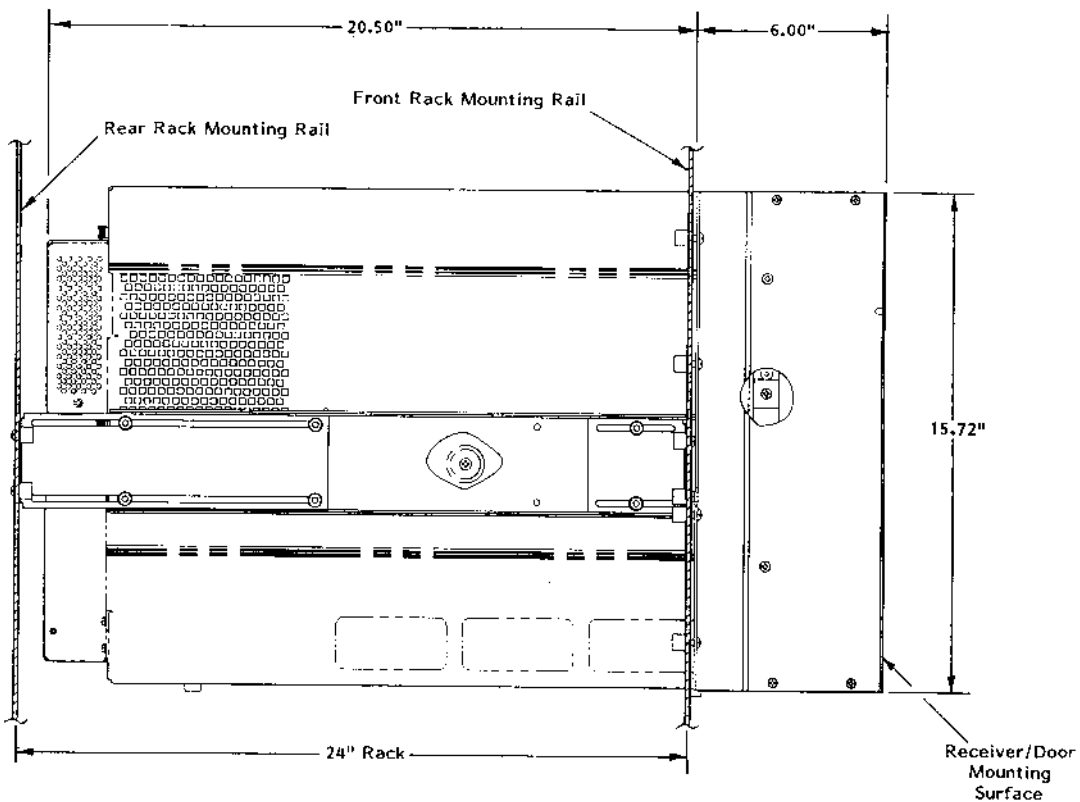

Figure A-6, Side View of 1261B 9U Mainframe With Option 54-2 Installed

Table A-8, SMS Monitoring System Specifications, (Typical)

Characteristics	Description								
Auxiliary Rear Panel DC Voltage Outputs	<table border="0"> <tr> <td>Voltage</td> <td>Current</td> </tr> <tr> <td>+5 V</td> <td>1 Amp maximum, (Self Healing Fuse)</td> </tr> <tr> <td>+12 V</td> <td>1 Amp maximum, (Self Healing Fuse)</td> </tr> <tr> <td>+24 V</td> <td>1 Amp maximum, (Self Healing Fuse)</td> </tr> </table>	Voltage	Current	+5 V	1 Amp maximum, (Self Healing Fuse)	+12 V	1 Amp maximum, (Self Healing Fuse)	+24 V	1 Amp maximum, (Self Healing Fuse)
Voltage	Current								
+5 V	1 Amp maximum, (Self Healing Fuse)								
+12 V	1 Amp maximum, (Self Healing Fuse)								
+24 V	1 Amp maximum, (Self Healing Fuse)								
Maximum slot temperature (Tmax) Rear Panel Output Voltage	100 mV per °C, 0°C corresponds to 0 V output ± 1.5 °C accuracy, -5 to + 85°C range								
Maximum slot Temperature Rise (ΔT) Rear Panel Output Voltage	100 mV per °C, 0°C corresponds to 0 V output ± 1.5 °C accuracy, -5 to + 85°C range								
Fan Speed TACH Rear Panel Outputs	2 Pulses/Rev, each fan has TTL level Tach output								
Fan Speed Range, typical	2000 to 4800 RPM								
VXI Power Supply Voltage Front Panel Health Status Readout	LED bi-color (red-green) annunciator green indicates supply within tolerance, red indicates supply out of tolerance, Tolerance limits: V nominal -8.75%, +10% 3% accuracy								
VXI Power Supply Current Front Panel Health Status Readout	LED bi-color (red-green) annunciator green indicates supply within tolerance, red indicates supply out of tolerance, Tolerance limits: 107 % of rated current, 7% accuracy, at full scale								
VXI Power Supply Temperature Front Panel Health Status Readout	LED bi-color (red-green) annunciator green indicates supply within tolerance, red indicates supply out of tolerance, Tolerance limits: ΔT > 20 °C, Tmax > 75 °C ± 1.5 °C accuracy								
VXI Power Supply Airflow Front Panel Health Status Readout	LED bi-color (red-green) annunciator green indicates supply within tolerance, red indicates supply out of tolerance, Tolerance limit: Fan speed > 900 RPM ± 100 RPM accuracy								

Table A-9, EMS Monitoring System Specifications, (Typical)

Characteristics	Description								
Auxiliary Rear Panel DC Voltage Outputs	<table border="0"> <thead> <tr> <th data-bbox="724 226 878 262">Voltage</th> <th data-bbox="878 226 1419 262">Current</th> </tr> </thead> <tbody> <tr> <td data-bbox="724 296 878 331">+5 V</td> <td data-bbox="878 296 1419 331">1 Amp maximum, (Self Healing Fuse)</td> </tr> <tr> <td data-bbox="724 331 878 367">+12 V</td> <td data-bbox="878 331 1419 367">1 Amp maximum, (Self Healing Fuse)</td> </tr> <tr> <td data-bbox="724 367 878 401">+24 V</td> <td data-bbox="878 367 1419 401">1 Amp maximum, (Self Healing Fuse)</td> </tr> </tbody> </table>	Voltage	Current	+5 V	1 Amp maximum, (Self Healing Fuse)	+12 V	1 Amp maximum, (Self Healing Fuse)	+24 V	1 Amp maximum, (Self Healing Fuse)
Voltage	Current								
+5 V	1 Amp maximum, (Self Healing Fuse)								
+12 V	1 Amp maximum, (Self Healing Fuse)								
+24 V	1 Amp maximum, (Self Healing Fuse)								
Maximum slot temperature (T_{max}) Rear Panel Output Voltage	100 mV per °C, 0°C corresponds to 0 V output ± 1.5 °C accuracy, -5 to + 85°C range								
Fan Speed Control	0V = Minimum fan speed 1V = Maximum fan speed ± 1.5 °C accuracy, -5 to + 85°C range								
Fan Speed TACH Rear Panel Outputs	2 Pulses/Rev, each fan has TTL level Tach output								
Fan Speed Range, typical	2000 to 4800 RPM								
VXI Power Supply Voltage Health Status Readout	Available at : Front Panel Display, VXI Message Based Interface, RS-232 interface Default Tolerance limits: V nom -8.75%, +10% 3% accuracy								
VXI Power Supply Current Health Status Readout	Available at : Front Panel Display, VXI Message Based Interface, RS-232 interface Default Tolerance limits: 107 % of rated current 7% accuracy, at full scale, typical								
VXI Power Supply Temperature Health Status Readout	Available at : Front Panel Display (1 x 10 Characters), VXI Message Based Interface, RS-232 interface Absolute Temp. = 55 °C Default Tolerance limits: $\Delta T > 30^{\circ}\text{C}$, $T_{amb} > 55^{\circ}\text{C}$ ± 1.5°C accuracy, -5 to + 85°C range								

Characteristics	Description
VXI Power Supply Airflow Health Status Readout	Available at : Front Panel Display (1 x 10 Characters), VXI Message Based Interface, RS-232 interface Tolerance limit: 2000 RPM < Fan speed < 5000 RPM ± 200 RPM accuracy
Rear Panel Trigger Input	TTL level Input (5VDC max), active low Routes to any one of eight backplane TTLTRIG lines (default is unconnected). Routing delay 50 nS, typical Programmable delay range: 0 nS to > 1 Second, 31.25 nS resolution, synchronization error 31.25 nS
Rear Panel Trigger Output	TTL level Output, active low, 74F38 driver with 1K Ohm pull up to +5V Routes from any one of eight backplane TTLTRIG lines or Real Panel Trigger Input (default is unconnected). Routing delay 50 nS, typical Programmable delay range: 0 nS to > 1 Second, 31.25 nS resolution, synchronization error 31.25 nS
Elapsed Time Functions Fan Service Power-On Time Cumulative Power-On Time	1 Second resolution 1 Second resolution 1 Second resolution
VXI IACK<N> Event Count	1 Count resolution, 0 to 255 range
VXI Bus Error Event Count	1 Count resolution, 0 to 255 range
VXI SYSFAIL*, ACFAIL*, and AS* Logic State Monitor	State Indication: 1 if the line is high, or a 0 if the line is low. (Note that since each of these lines is asserted when low, the normal reply should be "1").
Front Panel User Message	80 Characters, scrolled

Characteristics	Description
VXI Interface Capabilities	VXIbus Specification Rev 2.0 compliant Message-Based Device A16 Only Servant only Static Configuration Instrument Protocol (I) IEEE-488.2 Instrument Protocol (I4) Supports the Word-Serial Trigger command Programmable Interrupter Event Generation Response Generation
Software Protocols supported by VXI and RS-232 Interfaces	SCPI Compliance 1994.0 IEEE 488.2

Appendix B

ERROR MESSAGES

Error Messages

In general, whenever the EMS receives an invalid SCPI command, it automatically generates an error. Errors are stored in a special error queue and may be retrieved from this buffer one at a time. Errors are retrieved in first-in-first-out (FIFO) order. The first error returned is the first error that was stored. When you have read all errors from the queue, the generator responds with the message:

0,"No error"

If more than 16 errors have occurred, the last error stored in the queue is replaced with:

-350,"Queue overflow"

No additional errors are stored until errors are removed from the queue as described in the following paragraphs.

The error queue is cleared when power has been shut off or after a *CLS command has been executed. The *RST command does not clear the error queue. Use the following command to read the error queue:

SYSTEM:ERRor?

All errors have the following format (the error string may contain up to 80 characters):

<Error Number>, <Error String>

Where:

<Error Number> is a numeric value. This may be positive or negative

<Error String> is a descriptive error message, enclosed in double quotes.

A complete listing of the errors that can be generated by the EMS is shown in **Table 4-3**.

Table B-1, Error Messages

Error Message	ESR Bit Set	Error Description
0,"No Error"	none	The error queue is empty.
-100,"Command error"	CME	The command is not recognized.
-101,"Invalid character"	CME	There is an invalid character embedded in the command.
-102,"Syntax error"	CME	An unrecognized command or data type was encountered.
-103,"Invalid separator"	CME	The parser was expecting a separator and encountered an illegal character.
-104,"Data type error"	CME	The parser encountered a parameter data type different than expected. (For example, expected numeric/received string).
-105,"GET not allowed"	CME	A Group Execute Trigger was received within a command.
-108,"Parameter not allowed"	CME	More parameters were received than were expected.
-109,"Missing parameter"	CME	Fewer parameters were received than expected.
-110,"Command header error"	CME	An error was detected in the header.
-111,"Header separator error"	CME	An illegal separator character followed the command header.
-112,"Program mnemonic too long"	CME	The command keyword contains more than 12 characters.
-113,"Undefined header"	CME	Command header is syntactically correct but not recognized.
-114,"Header suffix out of range"	CME	The value of a numeric suffix makes the header invalid (VOLT8).
-120,"Numeric data error"	CME	The data appears to be numeric but is syntactically incorrect.
-121,"Invalid character in number"	CME	An invalid character for the data byte was encountered.
-123,"Exponent too large"	CME	The magnitude of the exponent was larger than 32000.
-124,"Too many digits"	CME	The mantissa of a decimal number contains more than 255 digits.
-128,"Numeric data not allowed"	CME	A legal numeric data element was received but is not allowed.
-130,"Suffix error"	CME	The command suffix is not understood or recognized.
-131,"Invalid suffix"	CME	The suffix does not follow the syntax in IEEE-488.2, Sec 7.7.3.2.
-134,"Suffix too long"	CME	The suffix contains more than 12 characters.
-138,"Suffix not allowed"	CME	A suffix was encountered after a numeric parameter value where no suffix is allowed. (e.g. " *SRE 255 MHZ").
-140,"Character data error"	CME	A character received as a command parameter is invalid.

-141,"Invalid character data"	CME	The character data element has an invalid character or the character data is not valid for the command header.
-144,"Character data too long"	CME	The character data element contains more than 12 characters.
-148,"Character data not allowed"	CME	A legal character data element was received but is not allowed.
-150,"String data error"	CME	A string received as a command parameter is invalid.
-151,"Invalid string data"	CME	A string was received where expected, but contained an invalid character (e.g. was not terminated with a quote character).
-158,"String data not allowed"	CME	A string data element was encountered but is not allowed.
-200,"Execution error"	EXE	An execution error has occurred. The EMS cannot determine a more specific problem with the error (see errors -201 to -299 below).
-210,"Trigger error"	EXE	A trigger error has occurred. No more specific info is known.
-211,"Trigger ignored"	EXE	*TRG or GET received but ignored due to timing considerations.
-212,"Arm ignored"	EXE	An arming signal was received and recognized but was ignored.
-213,"Init ignored"	EXE	A request for measurement initiation was ignored since another measurement was already.
-214,"Trigger deadlock"	EXE	Trigger subsystem is deadlocked.
-215,"Arm deadlock"	EXE	Trigger arming is deadlocked.
-220,"Parameter error"	EXE	Command parameter is invalid or unrecognized.
-221,"Settings conflict"	EXE	Legal command parameter received but could not be executed because doing so would place the device in an invalid state.
-222,"Data out of range"	EXE	Command data parameter is out of range.
-223,"Too much data"	EXE	Block, expression, or string type received contained too much data.
-224,"Illegal parameter value"	EXE	The parameter value is not from list of possible values.
-240,"Hardware error"	EXE	An (unspecified) hardware error prevented proper execution of the command.
-241,"Hardware missing"	EXE	The command failed because a hardware option was not installed.
-300,"Device-specific error"	DDE	A generic device-specific error which does not match one of the SCPI-defined errors in the range -300 to -399 has occurred.
-310,"System error"	DDE	A device-defined generic system error has occurred.

-311,"Memory error"	DDE	The EMS's memory is corrupted.
-314,"Save/recall memory lost"	DDE	The *SAV or *RCL command has failed due to a corrupted nonvolatile memory.
-315,"Configuration memory lost"	DDE	Configuration information has been lost due to a corrupted nonvolatile memory.
-330,"Self-test failed"	DDE	The self-test has failed. If this is set at power-up, execute the *TST? query to determine what has failed.
-350,"Queue overflow"	DDE	An attempt was made to add an error message to a full error queue. Thus, the error queue has overflowed.
-360,"Communication error"	DDE	A communication error has occurred over the RS-232 interface.
-361,"Parity error in program message"	DDE	A parity error has been detected in the command over the RS-232 interface.
-362,"Framing error in program message"	DDE	A framing error has been detected in the command over the RS-232 interface.
-363,"Input buffer overrun"	DDE	The RS-232 interface input buffer has been overrun.
-400,"Query error"	QYE	A query error has been detected.
-410,"Query INTERRUPTED"	QYE	The query has been interrupted (see IEEE-488.2, Sec. 6.3.2.3).
-420,"Query UNTERMINATED"	QYE	see IEEE-488.2, Sec 6.3.2.2 for a description.
-430,"Query DEADLOCKED"	QYE	The query has reached a deadlocked state. This happens when the input buffer is full, the output buffer is full, and a reply to a query cannot be generated.
1000,"VXI signal queue overflow"	DDE	The signal queue has overflowed. Sending VXI signals is an alternative method of generating interrupts.
1001,"VXI interrupt queue overflow"	DDE	The queue of pending interrupts to send has overflowed. The EMS maintains a queue of interrupts which should be sent. An interrupt cannot be sent until a previous interrupt has been acknowledged.
1002,"VXI bus error"	DDE	A VXIbus error has occurred when the EMS attempted to write data over the VXIbus.
1003,"VXI bus timeout"	DDE	A timeout has occurred while the EMS was waiting for control of the VXIbus.
1005 - 1999, "Internal error: xxx"	DDE	An internal firmware error has been detected. Errors of this type should be reported to Racal Instruments for correction.